

Reducing Feed Line Width for Optimal Electrical Parameters of a 1x4 Rectangular Microstrip Array

Özgür Dündar¹, Sinan Gültekin^{*2}, Dilek Uzer³

Submitted: 18/11/2019

Accepted : 11/12/2019

Abstract: Today, mobile devices are required to be portable in size and have long-lasting power supplies. For this reason, it is desirable that the components used in the devices have low power consumption, in particular the size of the antennas and that they meet the need for high band. In order to meet these needs, especially the intense increase in array antenna studies has been observed frequently in recent years. In this study, an array of 1x4 microstrip antenna elements was designed and produced. For this purpose, the study focused on the possible smallest width of the feed line considering the high antenna performance. Electrical parameters such as return loss, gain, directivity and radiation efficiency of the antenna array designed for KU Band region at 16 GHz resonance frequency were obtained and its performance was evaluated. In addition, the return loss, frequency and bandwidth of the antenna were calculated with Artificial Neural Networks (ANN). The ANN structure, which is trained with Multilayer Perceptron (MLP) network structure, is a 4-input, 3-output structure. Levenberg-Marquardt was used as the training algorithm in the calculation with ANN and tested for 8 measured values.

Keywords: Antenna array, HFSS, Ku Band, ANN, feed line optimization.

1. Introduction

Microstrip patch antennas that fulfill many wireless system requirements are widely used in handheld mobile devices and wireless communication systems. These antennas have wide application areas in mobile and satellite communications according to their advantages. Physically, a microstrip patch antenna is as shown in Figure 1. In its simplest form, called a ground plane on the metal coated dielectric substrate consists of a metal radiating patch. The metal parts are generally selected from a good conductive metal such as copper or gold. The thickness (t) of groundplane and patch varies between 50 and 200 μm . The thickness h of the dielectric structure varies between 0.25 mm and 25 mm. An important feature of the antenna, which can be defined as emitting or receiving devices, is the ability to focus and shape the power emitted in space. The structural and electrical system requirements of today's technology necessitate the antennas to be quite small and light. In addition, they can be easily mounted on solid surfaces from antennas, can be produced at low cost by using the advantages of printed circuit technology, be able to operate in multiple frequency regions, have linear and circular polarity radiation, have low scattering intersection, compatible with MMIC (Monolithic Microwave Integrated Circuit Design) designs and they are regular conductor structures, solid state devices such as oscillators, amplifiers, variable attenuators, switches, modulators, mixers, phase changers, etc. can be mounted on the bottom of the antennas, compound systems can be developed, feeder lines and matching circuits can be produced simultaneously with the antenna. Requirements are

expected. Microstrip antennas that conform to this definition are now widely designed and used. However, besides the advantages mentioned above, microstrip antennas have disadvantages such as narrow bandwidth, low efficiency, low power, high Q (sometimes more than one hundred), insufficient polarization purity, insufficient scattering performance, false feed radiation, and large physical dimensions of designs at low frequencies. In addition to intensive studies on these disadvantages, especially on the need for high gain, array antenna studies have increased considerably in recent years. The basic logic of a series of antennas is to increase the gain by increasing the electrical dimension with the elements in the array. The radiation diagram of an array of identical antenna elements depends on the geometric shape of the array antenna (linear, circular, spherical, etc.), the distance between the array elements, the amplitude and phase of the supply of the array elements, and the radiation diagram made by the array elements alone [5].

Using these advantages of microstrip arrays, in this study, a 1x4 microstrip antenna array for the 16 GHz frequency region, which is a KU band application, was conducted to reduce the antenna size. Working in this area, Khan O. M. , Ahmad Z. , Islam Q. [1] have designed antennas on single, 1x2, 1x4 and 2x2 rectangular microstrip patch arrays. It has been shown that as the number of patches increases in the antennas they designed, the gain and directivity also increase.

Following the completion of the basic 1x4 microstrip patch array design for size reduction process, the optimal adaptation was achieved by changing the feed line width and lengths without using any impedance matching method available in the literature. The feed line size to get the best results with about 26 antennas designed and conducted simulations and corresponds to the smallest size were obtained with good electrical performance antennas. The best results among the 26 antennas of the antenna no. 8 is taken from the production. Antenna design and simulations were performed by using HFSS (High Frequency

¹Satellite Eng. , Necmettin Erbakan University, Konya – 42080, TURKEY
ORCID ID: 0000-0002--4142-4446

²Elect. Electronic Eng. , Konya Technical University, Konya – 42075,
TURKEY, ORCID ID: 0000-3343-7165-777X

³Elect. Electronic Eng. , Konya Technical University, Konya – 42075,
TURKEY, ORCID ID: 0000-0003-3850-3810

Structural Simulator) simulation program which makes the solution of electromagnetic structures by finite element method and then its production was realized. The designed 1x4 rectangular array patch antenna elements, having a thickness of 0.254 mm, 2.2 dielectric constant value, is Duroid 5880. In order to avoid radiation interference, the distance between the elements was 0.428λ .

The performance of the antennas was evaluated and electrical parameters such as return loss (S_{11}), gain, directivity and radiation efficiency were obtained. Experimental devices for measurements were prepared in a laboratory environment using Network Analyzer. The antenna results obtained were compared with the literature and shown in the Table 3. In this study, the return loss, frequency and bandwidth of the antenna which is produced and designed is calculated by using Artificial Neural Networks (ANN). The ANN structure, which is trained with the Multilayer Perceptron (MLP) network structure, is a 4-input 3-output structure. ANN with Levenberg-Marquardt [8] training algorithm as the calculation using 47 trained with data simulation and tested with 8 measured values. The results are evaluated and presented in the Table 3,4 and 5.

2. Rectangular Microstrip Antenna Design

Rectangular microstrip patch antenna is the simplest microstrip patch structure. As it is shown in Figure 1, the main antenna member, the rear face coated with a ground plane, h thickness and ϵ_r on a base having a dielectric constant ($L \times W$) conductor with a dimension of a strip and an extension of the transmission line.

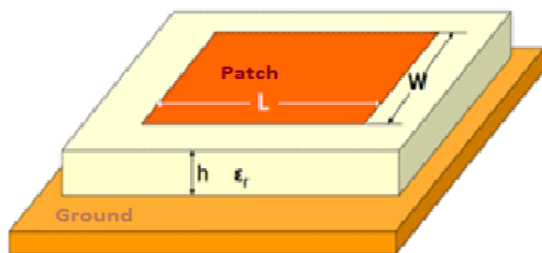

Fig 1. A rectangular patched microstrip patch antenna

W Patch width can be found by the following formula [2].

$$W = \frac{c}{2f_r} \left(\frac{\epsilon_r + 1}{2} \right)^{-\frac{1}{2}} \quad (1)$$

In the formula, c is the propagation speed of light in the void, ϵ_r is the dielectric constant of the material and f_r is the operating frequency. The patch length L from the half wavelength length of the fringing field (Δl) is obtained by subtraction.

$$L = \frac{c}{2f_r \sqrt{\epsilon_e}} - 2\Delta l \quad (2)$$

In the formula ϵ_e is the effective dielectric constant and for $(W/h) > 1$;

$$\epsilon_e = \frac{\epsilon_r + 1}{2} + \frac{\epsilon_r - 1}{2} \left[1 + \frac{12t}{W} \right] \quad (3)$$

to be calculated [3]. The t value in the equation is the microstrip line thickness.

If the line expansion is Δl ;

$$\Delta l = 0.412h \frac{(\epsilon_e + 0.3) \left(\frac{W}{h} + 0.264 \right)}{(\epsilon_e - 0.258) \left(\frac{W}{h} + 0.8 \right)} \quad (4)$$

It was expressed as [4].

2.1. Antenna Return Loss

Since the signals to the antennas are usually very small, the return loss is very important. The unit is dB because it is shown on a logarithmic scale. The standing wave ratio (SWR) is smaller than 2, it means that the return loss is smaller than -9.5 and the antenna can also operate at the resonance frequency. Return loss is calculated as follows [5].

$$RL = -20 * \log \left(\frac{VSWR - 1}{VSWR + 1} \right) \quad (5)$$

2.2. Antenna Band Width (BW)

The frequency range in which the return loss is less than -10 dB is accepted as the region where the antenna can work effectively. Bandwidth, center frequency as the ratio of the effective operating frequency range can be expressed in percentage form.

$$BW = \frac{f_{max} - f_{min}}{f_o} \times 100 \quad (6)$$

2.3. Antenna Gain

The gain of the antenna is one of the most important parameters to define its performance. Gain is the ratio of the radiation intensity of the antenna in a specified direction to the average of the radiation intensity received from all other directions. Antenna gain is calculated using how much power is transmitted from the electric fields in space to the antenna terminals.

$$G(\theta, \phi) = \frac{\rho(\theta, \phi)}{\frac{P_d}{4\pi r^2}} = \frac{P_r}{P_d} \times \frac{\rho(\theta, \phi)}{\frac{P_r}{4\pi r^2}} = \eta D(\theta, \phi) \quad (7)$$

2.4. Antenna Efficiency

Antenna efficiency is defined as the ratio of the power drawn from the source of radiation power. Some of the power drawn from the source is dissipated as thermal losses within the antenna. Thermal losses are caused by reflection losses, ohmic losses and losses due to the structure of the antenna. It reduces the antenna efficiency is more than the losses. Antenna efficiency is defined between 0 and 1 and is desirably close to 1.

$$e_0 = e_0 e_r e_d \quad (8)$$

3. Array Antenna

The radiation pattern of a single element antenna elements is relatively large, but only provides a low gain value. Most of the applications in order to meet the needs of long-distance communication is necessary to design a high-gain antenna. By increasing the electrical size of the antenna, the gain of the antenna can be increased. However, the antenna gain can also be increased by placing the radiating element in a certain electrical and geometric arrangement. This structure consisting of more than one radiation element is called an antenna array. The radiation diagram of a series of antennas consisting of identical antenna elements depends on the geometric shape of the array antenna (linear, circular, spherical, etc.), the distance between the array elements, the amplitude and phase of the supply of the array elements, and the radiation pattern alone of the array elements [6].

Microstrip antenna arrays can be designed in one-dimensional, two-dimensional or three-dimensional, depending on the dimensions of the space in which radiation is desired. Çakır [7] in her study of array antennas in the analysis and synthesis of array antennas to be easier to mention the necessity of preferring smooth geometries. Accordingly, the simplest form of geometry is linear arrays of equal distance in a single dimension, whereby the antennas are located on a single line at equal distance between them. Microstrip antenna array of the light and of low cost because of the likelihood Ku Band used over a wide range of applications. KU Band microstrip patch antenna can be used for VSAT (Very Small Aperture Terminal), Radiometric Ground Based Fire Detection, Micro Electromechanical Systems, Light Radar.

4. Artificial Neural Networks

Artificial Neural Networks (ANNs) are the approaches that try to form a new system by taking a model of the functioning of the human brain to itself. It is a highly simplified model of the human brain. The point where all Artificial Neural Network structures are inspired without exception is the operation method of biological neural networks. Artificial neuron, biological neuron input is designed to simulate the operation and the output characteristics.

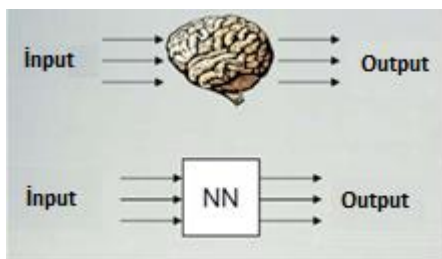

Fig 2. Artificial neural networks are inspired by biological neural networks.

In other words, Artificial Neural Networks (ANNs) are computer systems designed to solve new problems in the light of the information they have learned with an approach that imitates the human brain.

Artificial neural networks are the most important features of the human brain, which are capable of doing learning. Just as in the human brain, Artificial Neural Networks can also learn, solve new problems with the knowledge they have learned, gain experience with what they have learned, and artificial neural networks, like the human brain, can also make mistakes.

Here, each input is multiplied by its own weight and all of these products are added together. This sum is used to determine the level of activation of the neuron. The simplest network structure is a single layer structure. Multilayer networks have proven to be more excellent than single layer networks, and all studies have focused on these networks. Multilayer networks consist of a combination of single layer networks.

4.1. Multilayer Perceptron (MLP) ANN Structure

MLP, as shown in Figure 3, an input layer consists of one or more intermediate layers and an output layer. The processor elements in the input layer distribute the input signals to the processor elements in the intermediate layer. The processing elements in the intermediate layer are collected after the inputs from the input layer are multiplied by the link weights and passed through a transfer function and transferred to the output layer.

The processor elements in the output layer act as intermediate layer elements to calculate the network output value.

This study also used ANN-MLP network structure, the resonance frequency of the design and manufacture of electrical parameters of the treated array antenna (f_r), return loss (S_{11}) and the bandwidth (BW) is calculated. According to the algorithm used to train the weights until the error spread backwards and minimum error between the desired output with the output of the web has changed.

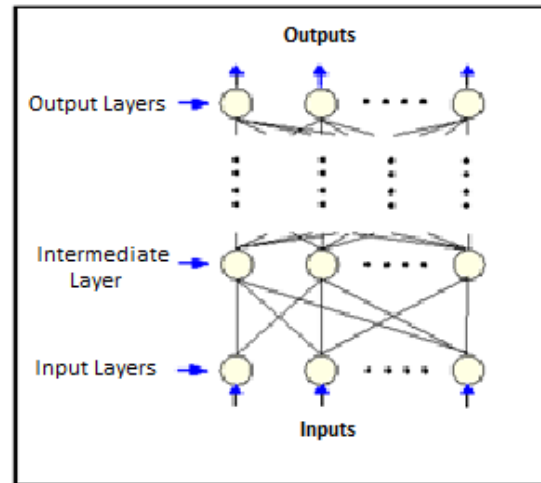

Fig 3. MLP network structure

There are many learning algorithms in the literature. These algorithms vary according to ANN structures. In this study, Levenberg-Marquardt (LM) [8,9] algorithm is used.

4.2. Levenberg-Marquardt (LM) Algorithm

It is one of the back propagation algorithms used in learning. It is based on a large number of neighborhood ideas. The least squares approach is a method based on a combination of the most important properties of the Gauss-Newton and Steepest Descent methods and the Hessian matrix approach. One of the most important advantages of LM is that it provides a better approach to the Gauss-Newton method with its rapid convergence. For example, if the Hessian (H) of the error value function is not positive, the direction defined in the Hessian matrix cannot be a descent function for the error value function. In this case, the step cannot be performed along the direction. The Marquardt, Steepest Descent (Gradient) and formed a method of Gauss-Newton method with desired properties and proposed to change direction. Accordingly, the Hessian matrix

$$H = J^T J \quad (9)$$

is estimated by (9)

$$g = J^T e \quad (10)$$

can be calculated as (10). Wherein the Jacobian matrix containing the first derivative of the error weight and bias network located on the J , ' e ' network error vector, and T represents the matrix transpose. By this method show a tendency to decline in the performance function of the algorithm in each iteration and J matrix (instead of the Hessian matrix) uses. According to this,

$$X_{k+1} = X_k - [J^T J + \mu I]^{-1} J^T e \quad (11)$$

is expressed as. If μ is greater, the minimum approach step is small. Therefore, the μ value should be reduced with each successful step. If the performance function increases, μ should be increased.

5. 1X4 Rectangular Microstrip Patch Antenna Array Design for 16GHz Band

The 16 GHz band for Ku designed microstrip patch antenna using Duroid 5880 1x4 material is aimed to improve their electrical parameters. Duroid 5880 substrate properties selected for the design shown in Table 1 and Equation 1, 2, the results calculated with the design formulas in Equation 3 and 4 are given in Table 2.

Table 1. Duroid 5880 Specifications

Material Properties	Value
Substrate	Duroid 5880
Dielectric Constant (ϵ_r)	2.2
Dielectric Thickness (h)	0.254 mm
Copper Thickness (t)	0.035 mm

Table 2. Calculated physical parameters

Microstrip Antenna Dimensions	Value
Width (W)	7.412 mm
Length (L)	6.462 mm
Effective Length (L_{eff})	6.729 mm
Effective Dielectric Constant (ϵ_{reff})	2.105

Following the completion of the basic 1x4 microstrip patch antenna design, optimal adaptation was achieved by changing the feed path thickness and length without using any impedance matching method in the literature. For this, the microstrip structure is used in Figure 4. Upon completion of the basic 1x4 microstrip patch antenna design, impedance matching method of modifying any thickness and length of the supply passage is provided in the literature without making optimal harmonization (Figure 5) [10].

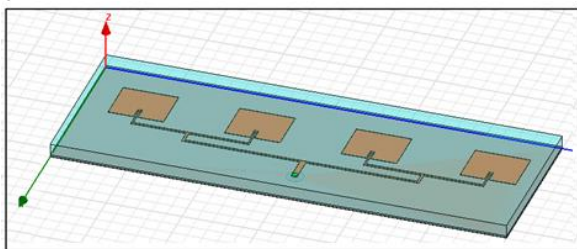

Fig 4. 1x4 Microstrip patch antenna

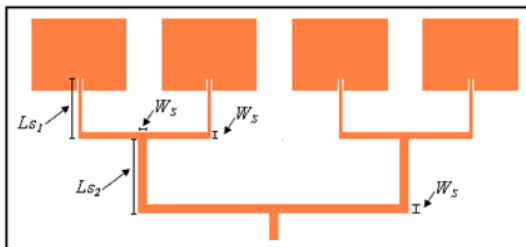

Fig 5. The proposed structure for improving antenna parameters

The initial improvement was made by reducing the feed way widths and lengths (W_s, L_{s1}) from 3.7594 mm to 2.6316 mm, decreasing 0.3759 mm and increasing the W_s width from 0.30 mm to 0.70 mm for each L_{s1} value. 44 arrays were produced. Each of these antennas is individually simulated. Resonance

frequencies (f_r), loss of recycle (S_{11}), bandwidth (BW), directivity (D), gain (G) and radiation efficiency (e_0) were determined.

L_{s1} length of 3.3835 mm value of the antennas designed for return loss, bandwidth, gain and directivity was obtained at the highest value. Therefore, in the second stage of the improvement, the L_{s1} length is kept constant at 3.3835 mm and the intermediate length L_{s2} value is changed to 3.4267mm to 1.8267 mm with 0.4 mm intervals and feed widths are changed from 0.38 mm to 0.70 mm with 0.04 mm steps. Thus, 47 new antennas were designed. Design of the final group $L_{s2} = 1.8267$ mm at a width value than the two steps to the exit of the best results is made by reducing the width of the minimum point improvement. As a result of this study, the values obtained from the simulations are presented in Table 3.

Simulation results giving the best value L_{s2} according to the data value (bold) was determined. 8 antennas are produced and measured. The measurements were made with Anritsu MS2038C mobile VNA in the Communication Laboratory of Medipol University. Measurement results and other corresponding results are given in Table 4. According to Table 3 and Table 4 and based on smallness, the best antenna is the 38th (dark) antenna. Figure 6 shows the smallest (7 rows) of the 8 antennas produced.

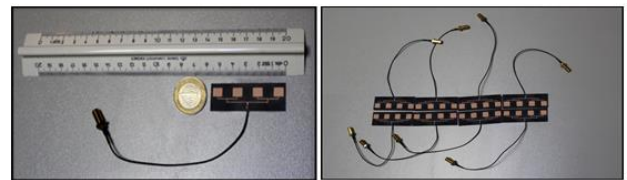

Fig 6. A sample of 8 1x4 microstrip array antennas produced

Figures 7 and 8 show the S_{11} and gain (3D) graphs of these antennas. As shown in the figures, the frequency is 16.12 GHz, S_{11} -38 dB, BW 450 MHz and G is 11.20 dB.

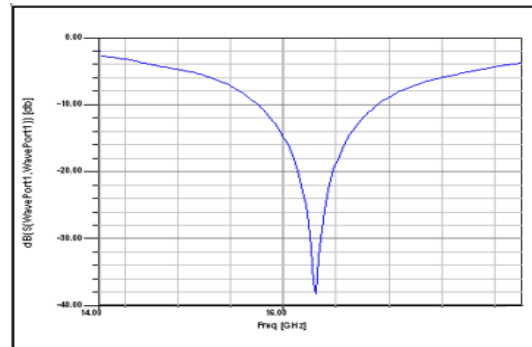

Fig 7. S_{11} Return loss

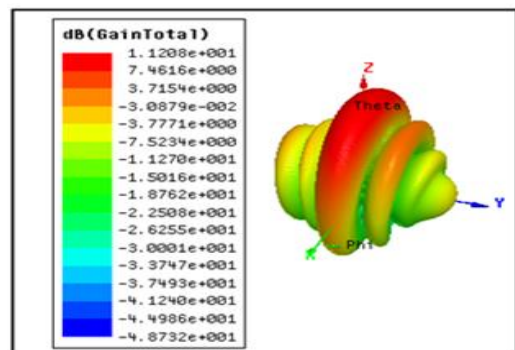

Fig 8. 3D gain

Table 3. Simulation results of 47 array antennas made with second improvement

No	L_{s2} (mm)	W_s (mm)	f_r (GHz)	S_{11} (dB)	BW (MHz)	D	G (dB)	ϵ_o
1	3.4267	0.38	16.057	-12.442	512	11.46	10.93	0.88
2	3.4267	0.42	16.056	-15.901	517	11.47	10.95	0.88
...
9	3.4267	0.70	15.995	-56.216	510	11.74	11.23	0.89
...
14	3.0267	0.54	16.065	-42.149	490	11.71	11.20	0.89
...
20	2.6267	0.42	16.065	-38.339	480	11.69	11.16	0.88
21	2.6267	0.46	15.223	-15.283	220	7.81	6.76	0.79
22	2.6267	0.50	16.045	-25.206	430	11.66	11.12	0.88
...
29	2.2267	0.42	16.115	-24.693	430	11.72	11.21	0.89
30	2.2267	0.46	16.125	-20.329	380	11.74	11.21	0.89
...
38	1.8267	0.34	16.155	-35.897	450	11.79	11.20	0.88
39	1.8267	0.38	16.135	-23.528	410	11.68	11.17	0.89
...
46	1.8267	0.66	15.253	-11.145	160	7.86	8.87	0.80
47	1.8267	0.70	15.245	-9.520	245	7.86	8.87	0.80

6. 16GHz 1X4 Rectangular Microstrip Patch Antenna Design Calculating S_{11} , f_r , BW Parameters Using ANN Types of Graphics

47 array antenna simulation results given in Table 3 were used to train ANN structure and 8 measurement results given in Table 4 were used to test ANN structure. Calculations four inputs using the MLP-ANN network structure is made using a structure of three outputs. Input parameters; dielectric constant (ϵ_r), dielectric base thickness (h), feed line length (L_s) and feed width (W_s). Output parameters are; resonance frequency (f_r), return response (S_{11}) and bandwidth (BW). In the ANN network structure, LM was used as the training algorithm.

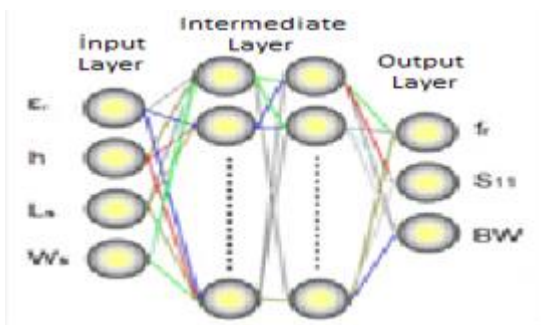

Fig 9. 16 GHz MLP-ANN Three-output network structure

Table 5 shows the input and output test set and ANN test results for the network with three outputs for the calculation of f_r , S_{11} and BW . The differences from the results are indicated. The best results for the MLP-ANN structure were obtained by determining

the number of 10x9 intermediate layers with 2000 iterations.

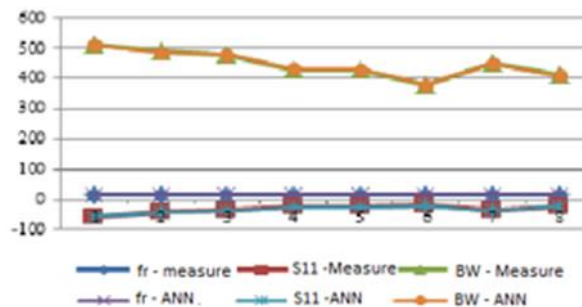

Fig 10. Measurement and ANN test curves obtained by three output MLP-ANN network structure

Figure 10 shows the measurement and ANN test curves obtained by the three-output MLP-ANN network structure.

7. Results and Discussion

In this study, a series of small size 1x4 microstrip antennas were designed and produced. For this purpose, it has been tried to make the most suitable smallest possible width of the supply line considering the high antenna performance. Ku Band antenna array designed in the region of the resonance frequency of 16 GHz, the return loss, gain, maintaining the electrical parameters such as directivity and light efficiency, performance was evaluated.

Also production and design of the return loss of the antenna structures, frequency and bandwidth, Artificial Neural Networks (ANN) are calculated. Levenberg-Marquardt [8] was used as the training algorithm for ANN calculation. According to the results obtained when the Table 3 is examined, the best center frequency, L_{s2} is 3. 4267 mm and 0. 66 mm W_s is seen to occur at 16. 005 GHz antenna. Table 4. 13 is examined in terms of bandwidth, L_{s2} is 3. 4267 mm and W_s is 0. 50 mm in the antenna number 4 is 698 MHz is seen. When Table 3 is examined in terms of recycling loss, L_{s2} is 3. 4267 mm and W_s is 0. 70 mm, the return loss in antenna 9 is -56. 216 dB is seen. Antennas 9, 14, 20, 22, 29, 30, 38 and 39, where the best electrical parameters were obtained for each value of L_{s2} , were selected for production and measurements. These antennas are given in Table 4.

16 GHz is used in the 1x4 array of patch antenna ANN invested in improving the electrical parameters. Antenna data was trained using two single MLP structures with one output and three outputs for both frequency studies.

16 GHz 1x4 arrays of patch antennas for MLP-single-output neural network 47 is trained by network simulation data was tested with 8 pieces of the measurement data. According to these results; f_r , S_{11} and BW total absolute error test results were found to be 0. 0007, 0. 019 and 2. 1, respectively. For three output structure, f_r , S_{11} and BW total absolute error test results were found to be 0. 003, 0. 0192 and 7. 6, respectively.

As can be seen from the tables and graphs, the return response, frequency and bandwidth of the 1x4 rectangular microstrip patch antenna at the 16 GHz frequency, which was trained with the Levenberg-Marquard [8] training algorithm, were calculated in the three-output MLP-ANN network structure and the results were quite good. The results show that ANN can calculate these parameters.

When the results were evaluated, ANN results were determined as the output parameters of MLP-ANN network structure;

resonance frequency, return response and bandwidth measurement results.

Table 4. Simulation results of 47 array antennas made with second improvement

Number	Sequence Number in Table 3	L_{S2} (mm)	W_S (mm)	Simulation Results			Measurement Results		
				S_{11} (dB)	f_r (MHz)	BW (MHz)	S_{11} (dB)	f_r (MHz)	BW (MHz)
1	9	3.4267	0.70	-56.22	15.995	510	-21.79	15.046	164
2	14	3.0267	0.54	-42.15	16.065	490	-26.96	15.088	129
3	20	2.6267	0.42	-38.34	16.065	480	-45.25	14.96	220
4	22	2.6267	0.50	-25.21	16.045	430	-41.97	15.037	120
5	29	2.2267	0.42	-24.69	16.115	430	-19.19	15.030	136
6	30	2.2267	0.46	-20.33	16.125	380	-25.74	15.118	226
7	38	1.8267	0.34	-35.9	16.155	450	-29.53	15.104	194
8	39	1.8267	0.38	-23.53	16.135	410	-54.97	15.076	143

Table 5. f_r , S_{11} and BW entry and exit test set of three outputs for computing and network ANN test results

Inputs				Outputs			ANN Outputs			Difference Absolute Error		
ϵ_r	H (mm)	L_s (mm)	W_s (mm)	f_r (GHz)	S_{11} (dB)	BW (MHz)	f_r (GHz)	S_{11} (dB)	BW (MHz)	f_r (GHz)	S_{11} (dB)	BW (MHz)
2.200	0.254	34.267	0.700	15.995	-56.220	510.00	15.9950	-56.2160	511.20	0.0000	0.0040	1.2000
2.200	0.254	30.267	0.540	16.065	-42.150	490.00	16.0647	-42.1490	486.10	0.0003	0.0010	3.9000
2.200	0.254	26.267	0.420	16.065	-38.340	480.00	16.0650	-38.3389	480.00	0.0000	0.0011	0.0000
2.200	0.254	26.267	0.500	16.045	-25.210	430.00	16.0450	-25.2060	432.40	0.0000	0.0040	2.4000
2.200	0.254	22.267	0.420	16.115	-24.690	430.00	16.1150	-24.6930	430.00	0.0000	0.0030	0.0000
2.200	0.254	22.267	0.460	16.125	-20.330	380.00	16.1250	-20.3290	380.00	0.0000	0.0010	0.0000
2.200	0.254	18.267	0.340	16.155	-35.900	450.00	16.1550	-35.8970	450.00	0.0000	0.0030	0.0000
2.200	0.254	18.267	0.380	16.135	-23.530	410.00	16.1350	-23.5279	410.10	0.0000	0.0021	0.1000
Total Test Absolute Error										0.003	0.0192	7.6000

References

- [1] Khan O. M., Ahmad Z., Islam Q., 2007, "Ku Band Microstrip Patch Antenna Array", 2007, IEEE, 1-4244-1494-6/07W. -K. Chen, Linear Networks and Systems. Belmont, CA, USA: Wadsworth, 1993, pp. 123-135.
- [2] James H., 1989, Handbook of Microstrip Antennas, 1989, London.
- [3] Schneider M., "Microstrip Lines for Microwave Integrated Circuits", BellSyst, Tegn J., 48, pp. 1421-1444, 1969.
- [4] Hammerstad E., Bekkadal F., 1975. A Microstrip Handbook, ELA Breport, STF44A74169, University of Trondheim, Norway
- [5] Pozar, D. M., 2005., Microwave Engineering, John Wiley & Sons, 691 s., USA.
- [6] Balanis C. A., 1997, Antenna theory Analysis and Desing, 2nd ed. John Wiley and Sons, New York 1997.
- [7] Çakır G., 2004, Beam Scanning MicrostripArray Antenna Desing For Mobile Communication Systems: Analytical Calculations, Computer Simulations and Measurements, İnstitut of Sciece, Kocaeli, 2004
- [8] Levenberg K., 1944, A Method For the Solution of Certain Nonlinear Problems in Least Squares, Quart. Appl. Math., 2, s. 164-168, 1944.
- [9] Marquardt D. W., 1963, An Algorithm For Least-Squares Estimation Of Nonlinear Parameters, J. Soc. Ind. Appl. Math , 11, s. 431-441, 1963.
- [10] Dündar Ö., 2017, Determination of Desing Parameters of Patch Antenna Array Using Neurel Networks, İnstitut of Sciece, Konya, 2017.