

An Overview on the Investigation of Power Quality Problems and Harmonic Exclusion in the Power System using Frequency Estimation Techniques

Krutuja S. Gadgil¹, Prabodh Khampariya², Shashikant M. Bakre³,

Submitted: 04/11/2022

Revised: 10/01/2023

Accepted: 31/01/2023

Abstract: The present research paper is based on a survey on the Investigation of Power Quality Problems and Harmonic Exclusion in the Power System using the Frequency Estimation Technique. The majority of FD approaches are open-loop, and they are based on Fourier series analysis in most cases. When applied to frequency domain approaches, Fourier series analysis is a powerful mathematical tool that allows users to acquire a wide range of frequency components by multiplying the input by a set of trigonometric functions (sine/cosine) at various frequencies. Typically, the discrete implementation of the Fourier series, also known as the Discrete Fourier Transform, is used to compute results. DFT can be done quickly and simply using computer technology, and it can be used to estimate the grid signal parameters with improved selectivity and greater steady-state accuracy than other methods. The A/D conversion process of the input signals is required for the real-time implementation of the DFT, which necessitates the repeated sampling and updating of the input signals. However, in order to compute the N samples, this approach necessitates the use of N^2 complex multiplication and N^2-N complex addition. As a result, it was not extensively used prior to the introduction of the microprocessor.

Keywords- Power Quality, Harmonic Exclusion, Power System, Frequency Estimation Technique, Discrete Fourier Transform.

1. Introduction

Throughout the previous decades, electrical utility has seen a significant shift in the areas of electrical power production, transmission, and distribution. It has emerged primarily as a result of the deregulation and restructuring process, technological advancements, and greater public awareness about the environmental consequences.

It is no longer necessary to rely only on centralized power plants for energy production; instead, distributed energy resources (DERs) or distributed generators are permitted (DGs). A power electronic converter is often required for grid interface on distributed energy resources (DERs), as opposed to centralized power plants, which are linked directly to the utility. Various power converters (commonly referred to as FACTS devices) with fast and complex controls are also included in the system to increase the transmission and distribution capacity of the power system while also improving its stability. Not only the supply system, but also domestic and industrial consumers have contributed to the increase in power converters to meet the

requirements of precise control, increased efficiency, and the need to comply with laws and regulations established by regulatory agencies, among other factors.

In addition to posing certain challenges in terms of design, authorization, operation, and control, these power transformers, which are intended to improve system power or load, also present some challenges in operation and control; if not, they can reduce the performance of the network or connected system. The severity of the challenges posed by these converters rises in direct proportion to the amount of penetration (number and size) of these converters in the current network. These challenges include synchronization to be done properly, control of power flow, injection of harmonics and / or imbalance, fluctuations in voltage and frequency, resonance, changes in network impedance, power flow in reverse direction, and other related concerns. As a result, it is necessary to develop an effective control mechanism for the converters in order to minimize the undesirable effects to a bare minimum.

When it comes to ensuring accurate operation and control of the converters, one of the most critical aspects to consider is the appropriate synchronization of the converters with the utility. A correct calculation of the phase, frequency, and maximum value of the voltage/current at the PCC is required in order to achieve this result. However, there are a number of non-idealities in the PCC voltage, particularly in the current power system, which is characterized by non-

¹Research Scholar, Department of Electrical Engineering, School of Engineering, SSSUTMS, Sehore, M.P.(India)

²Professor, Department of Electrical Engineering, School of Engineering, SSSUTMS, Sehore, M.P.(India)

³Associate Professor, Department of Electrical Engineering, AISSMS IOIT, Pune(India)

¹krutujagadgil@gmail.com, ²khampariya5@gmail.com,

³shashikant.bakare@aissmaioit.com

linear loads and DGs that are powered by power converters. Thus, an improper estimate of voltage/current phase and magnitude results ultimately has a negative impact on the converters' ability to execute their functions properly. In addition, harmonics and/or imbalances are introduced into the system, resulting in a reduction in the power quality of voltages and currents at the PCC and throughout the associated system.

2. Literature Survey

For the study purpose, we have selected some important research articles which as follows:

Abdoos, A. A., et al. (2016) [1] presented a new hybrid algorithm for PQ disturbances detection in electrical power systems. The proposed technique consists of the following : Power Quality events simulation, feature extraction and selection ,and feature categorization. Variational mode decomposition as well as S-transform are used to extract possible features from PQ events. It decomposes signals into modes and examines them in time and frequency domains. To eliminate duplicate features, wrapper-based techniques such as sequential sequencing (SFS) and sequential retrieval options (SBS) are utilised, as well as a Gram-Schmidt based feature selection method as the filtering method. SVMs are employed as the classifier core to distinguish PQ events. The thorough experiments show that, even in noisy environments the suggested technique work well in terms of speed and accuracy. PQ event start and endpoints may also be recognized precisely.

Abdullazyanov, E. Y., et al. (2015) [2] investigated the problem of developing robust mathematical methods for calculating high harmonic formation. Harmonics of higher order are crucial in power networks nowadays because they increase responsibility of power suppliers towards customers. The first and most important reason is that it provides a solution to the issue of energy conservation. In addition, the demarcation of accountability for ensuring the appropriate power quality among the electrical supply business and its consumers is an important consideration.

Alfieri, L., et al. (2017) [3] developed new power quality indicators for the evaluation of distortions in waveform in the frequency range of 0 - 150 kHz. In particular, several already accessible indices have been correctly changed in order to allow them to be applied to waveforms with a broad range of frequency responses. In the case of renewable energy sources, numerical applications demonstrate that the proposed indicators are excellent problem-solving tools. (such as overheating, mechanical breakdown, loss owing to skin effects or eddy currents) where both low as well as high distortion in frequency are a concern.

Almutairi, M. S., & Hadjiloucas, S. (2019) [4] developed a novel approach for controlling distortions in non-sinusoidal systems by estimating the value of the shunt single-tuned

passive filter compensator using non-linearity current index (NLCI), with the intention of keeping the power factor within acceptable limits. At point of common coupling, the suggested approach seeks to reduce the indirect amount of the customer load in the electrical power system to a maximum capacity (PCC). The proposed design also takes into account some practical power barriers and limitations of each harmonic distortion, ensuring compliance with IEEE 519 - 2014 guidelines, keeping the distortion at a reasonable level while following the loading of capacitor barriers established by IEEE 18 - 2012. A well-documented IEEE standard is used to evaluate the performance of the ideally built compensator. This standard is based on numerical examples of loads that were nonlinear in nature which were collected from prior publications.

Al-Ogaili, A. S., et al. (2020) [5] offered thorough research and analysis of the performance of two well-known harmonic extraction in the time domain strategies, synchronous reference frame theory, and instantaneous power theory, respectively. The MATLAB-Simulink platform is used to undertake extensive simulation work are conditions under steady as well as dynamic state ,while taking into account a variety of highly nonlinear loads and parameters. Specifically, each control method is included in a three-phase SAPF controller that was constructed with the help of a three-level neutral point clamped inverter to serve as an assessment platform. Comprehensive data are supplied to demonstrate the effectiveness of the SAPF's mitigation performance when each harmonic extraction method is used.

Askarian, I., et al. (2017) [6] centered on the development of a system for detecting and monitoring disruptions and oscillations in the electric power grid. They described a unique real-time harmonic estimation approach that is capable of swiftly and accurately estimating the dc component, as well as the harmonic contents of the grid voltage, both synchronous and asynchronous, despite the fact that the nature of the unknown harmonic contents is unknown. The suggested approach may be used in the power converters' control system, which has the potential to improve the dependability and resilience of future micro-grid systems. The execution of the suggested harmonic estimator is tested in the context of power converter grid synchronization, which is used as a case study. The findings of the case study's simulations and experiments demonstrate that the converter has the capacity to deliver a sinusoidal current even in the face of disturbances and variations in the voltage of the grid . The obtained findings demonstrate that the suggested harmonic estimation approach is both dynamic and accurate in a short period of time.

Bajaj, M., et al. (2020) [7] suggested a process of analytic hierarchy (AHP) inspired by the PQ test method for distorted energy distribution in the presence of renewable DG, systems. The suggested PQ evaluation technique considers four PQ phenomena: harmonics in voltage, sags and

imbalance in voltage, and voltage profile at each bus in the steady-state condition. The technique is implemented on modified 13 bus (IEEE) test distribution system which has loads of nonlinear nature and DG systems which are based on photovoltaic, fuel cell, wind, and RES using MATLAB. Findings validated approach's effectiveness in measuring each bus's total PQ performance and comparing it against the unity threshold level. According to the findings, a comparison of DN PQ performance with three RES-based DGs is made. The developed index is also used to study the influence of using custom power devices (CPDs) and excessive renewable energy penetration on distribution network PQ performance.

Baraniak, J., & Starzyński, J. et al. (2020) [8] produced measurement-based simulation models taken from the actual charger and data which is provided by the equipment's producers, as well as simulation models that have been extensively described in the literature; and It was determined, based on the study's findings, if electric car chargers had a negative influence on the quality of electric power, and thought was given to the opportunities presented by the development of charging systems with vehicle to grid capabilities. Proposed standard changes include taking into account the heating of power supply cables under the impact of increased harmonics caused by current produced by converter systems while choosing power supply cables.

Blazek, V., et al. (2020) [9] introduced an analysis of the impact of domestic appliances on end-user energy quality. The research findings affect the ultimate customer (the lowest level of the power grid). The study used 120 grid-connected electrical appliance combinations. Each combination has three devices in a micro-grid. The gathered and the data which was analysed statistically showed that certain kinds of appliances had a large impact on variations in power quality characteristics. The results of the trials show the devices that impacted the THDV, FREQ, and voltage fluctuation (V). The importance of certain device characteristics on the power quality deviation was investigated. This highlighted the key aspects to consider while building a prediction model. This is the future of smart grids. One of the important features is the reduction of energy usage from renewable sources. This phenomenon is detailed in their work. They studied the impact of smart home equipment on individual amounts on an actual model. They also looked at gadgets that had a big influence on power quality. To increase the prediction model's usefulness, they explain their distinctive behavior and relevance to the occurrence.

Bottura, F. B., et al. (2019) [10] proposed an optimized allocation methodology of power quality (PQ) meters in a medium voltage distribution system, taking into account harmonic potential sound conditions. HRMA technique is used to compute critical modal impedances and detect frequencies of harmonic resonance. Using the HRMA, one

may create a binary observability matrix that includes node observability for hypothetical harmonic resonance frequencies. To ensure comprehensive observation of the specified harmonic resonance frequencies, allocation issue is modeled as a cinteger linear programming with constraint. The final practicable solution specifies the ideal sites to put PQ meters, considering harmonic resonance situations, DS operating scenarios, and client capacitor banks for PFC. The allocation mechanism was tested in two CIGRÉ MV test DSs and an IEEE 34 - node test feeder. To fully monitor frequencies of potential harmonic resonance in both test DSs requires four PQ meters. The final allocation solution is proven to be appropriate even when the capacitor banks are variable.

Brunoro, M., et al. (2017) [11] offered a novel idea for load modeling that incorporates the ZIP model as well as the admittance matrix across the board. As a result of this combination, the benefits of load characterization are combined with the traditional ZIP model, which provides some physical information about the load, and the frequency crossing, which is provided by an admittance matrix. With acquired information, harmonic power injection in the load bus can be properly computed, which is then used to calculate the harmonic voltage of the load bus. The current plan, however, includes a constraint for the ZIP coefficients in order to define the power ratio in terms of constant impedance, constant current, constant power, and constant resistance. An electronic load case study is presented, which includes a discussion of the process for selecting the parameters of the load model, which includes Multiple linear regression and exhaustive search. Data from a power quality meter is used to demonstrate the model's use in an electronic load. The results indicate that the proposed harmonic model accurately represented the load, and that the received parameters provided information about the type of model load that was represented.

Bubshait, A. S., et al. (2017) [12] studied a four-leg inverter linked to the integrated side to inject the readily available energy, and operate like a active filter which minimizes the disturbances in the load current and improves the quality of power. Linear and nonlinear loads (three-phase and single-phase) are examined. The utility-side controller compensates for disturbances induced by reactive, nonlinear, and/or unbalanced single as well as intra-phase loads, as well as delivering active and reactive power as needed. In the absence of wind power, the controller is designed to enhance power quality utilizing a dc link capacitor linked to the grid. The proposed control structure is unique in the literature in that it is based on conservative power theory decompositions. This option provides power and current references that are decoupled for inverter control, allowing for more flexibility and power. Real-time software benchmarking was used to assess the suggested control algorithm's performance in full real-time. The use of

a real - time simulator and a TMSF 28335 DSP microcontroller allows the control methods to be tested in hardware-in-the-loop. As a consequence, we were able to eliminate passive filters from our smart-grid-based control, making it more compact, adaptable, and dependable.

Buzdugan, M. I., et al. (2017) [13] outlined a few challenges developed in low voltage distribution grids at the end-user level as a result of power system harmonics at the end-user level. The introduction part briefly discusses harmonics sources, their analysis, effects, and measuring techniques, with a strong emphasis on the limitations specified in the individual standards as the primary reference. Two case studies of power electronics equipment with high distorted currents and, as a result, high harmonic content were provided by the authors. One of the examples is a piece of household equipment that is powered by a switch-mode power supply and has been tested in a laboratory setting. The second kind of drive, a variable speed drive, has been tested in an industrial setting, i.e. under real-world circumstances. Finally, harmonic measurements and analysis enable the selection or creation of retrofitting mitigation countermeasures that are capable of alleviating the impacts of harmonics.

Cai, W., et al. (2020) [14] The impact of the uncertainty principle on the issue of power quality monitoring was investigated, and the issue was solved using perfect atomic decomposition (IAD). Whereas the waveform of the power quality is detected by the new approach, it is done so using time and frequency pair as base. As a result, it is possible to decrease both temporal uncertainty and frequency uncertainty at the same time. The orthogonal matching pursuit method is used to implement the sensing process (OMP). According to the results of simulations and power quality tests performed on field, as well as comparisons made on the of developed methods, the new method is able to provide accurate analysis for a wide range of power qualities. The method has also been validated as a promising option for monitoring quality of power in substations that are smart.

Chokkalingham, B., et al. (2018) [15] For NPC-MLI, two multilevel pulse width modulation methods were considered: multicarrier sine PWM as well as space vector PWM (SVPWM). Different restrictions, such as common-mode voltage (CMV), profile of voltage, total THD, and neutral point fluctuation, are applied to both approaches and compared and assessed (NPF). When the SVPWM method is contrasted to the MCSPWM method, the findings indicate that the SVPWM method is better. FPGA SPARTAN III generation 3 AN XC3S400 with 2KW NPC MLI variable speed switch - the driving system is used to ensure the testing of the analysis and simulation obtained using MATLAB / Simulink on the control systems.

Christe, A. J., et al. (2020) [16] investigated the Open Power Quality (OPQ) project. Specifically, It intends to construct as well as deploy a distributed power quality sensor network of low cost, will offer producers, consumers, academics, and regulators meaningful new kinds of information about current electrical grids in real-time. In 2019, they conducted a three-month pilot study at the University of Hawaii microgrid, which included the implementation of an Open Power Quality sensor network. The findings of the pilot research confirm that the Open Power Quality (OPQ) system is capable of collecting reliable power quality data in a manner that provides significant new insights into electrical grids.

Das, S. R., (2020) [17] developed to eliminate the shoot-through effect (STE) and decrease distortions in the supply current, a three phase four wire multi-level inverter based APF. Using this approach, it is possible to regulate the voltage source inverter utilising Adaline based LMS (A-LMS) algorithm combined with a controller based on hysteresis current. Comparisons are made between the suggested filter, which makes use of the A-LMS approach, and the usual recursive least square algorithm. The A-LMS technique is primarily used for maintenance of the dc link voltage of multi level inverter, and it operates on the basis of the capacitor energy theory, which helps to decrease total harmonic distortion under a variety of load fluctuations. MATLAB/Simulink is used for the design, development, and validation of MLI's performance under a variety of load circumstances, the most important characteristics of the system are identified.

Filipović-Grčić, D., et al. (2017) [18] harmonic distortions and tests based on frequency response to find the harmonic levels produced by IVT and its ability to transform harmonics from the high voltage to the low voltage. Using complex voltages, which are made up of a fundamental voltage and a few harmonic voltages superimposed on them, the frequency response of IVT may be examined. The IVT's, RCFs and phase angle errors are calculated, and the results may be used to power quality monitors to compensate for mistakes that arise at high harmonic frequencies, as well as other applications. It is suggested that several test circuits be used to generate high-voltage (HV) fundamental voltage and harmonic voltage signals with amplitudes ranging from 5 to 15% of the applied fundamental voltage. In order to increase the testing capabilities of equipment operating at higher voltage levels, compensation for both fundamental and harmonic voltages is provided using a specific connection comprised of blocking and pass filters (for equipment operating at 123 kV Um 420 kV).

Gnacinski, P., & Tarasiuk, T. (2016) [19] presented a preliminary proposal to modify the power quality standards: EN 50160 characteristics of voltage characteristics of electricity which is supplied by public distribution network and EN - ICE 61000 -2 -4 Electromagnetic compatibility

(EMC) – Part 2 – 4: Environment Levels of compatibility in industries with low frequency conducted disturbances. In their suggestion, a comprehensive set of indicators is combined with a simplified coefficient of temperature of quality power, the value of which indicates the temperature increase in the windings of induction machines when the quality of supply voltage is degraded; The suggested upper and lower limit values of the coefficient are obtained by an examination of a variety of heating situations induction machine. In addition, the outcomes of factor monitoring in real-world power systems are discussed in their work.

Gokozan, H., et al. (2015) [20] presented an artificial neural network-based intelligent monitoring algorithm to detect power system harmonics. A LabVIEW - based measurement system was used to gather electrical parameters like voltage and current from an induction furnace, and the suggested technique was evaluated on the data under varied load situations. MATLAB software was used to evaluate the data obtained and determine the harmonics dominant in nature (power system). The power spectral density and short-time Fourier transform (FT) and techniques for estimation were used to determine the power system's dominant harmonics. After determining the operating area which are in full load situation in terms of harmonic levels, it was necessary to employ the power spectral density method in order to determine stationary intervals in the power system's data. It was necessary to identify harmonic frequencies in order to put the artificial neural network method through its paces. The algorithm was then evaluated for harmonic estimation under a variety of load situations. As a result, the neural network's topology was used as an artificial follower. The findings show that an error fluctuation at the auto-associative neural network's output can be used to accurately estimate the harmonic state of a power system in real-time.

Gorjani, O. M., et al. (2019) [21] studied power engineering computing; power grids; distribution networks; power supply quality; invertors; distributed power generation; static VAr compensators; photovoltaic power systems; smart power grids; power transformers.

Hafezi, H., & Faranda, R. (2017) [22] introduced the definitions of PQ as well as CP and seeks to find the same possible answer for distribution system operators and the end users for whom electrical power plays a key role. The use of sources of renewable energy and energy storage devices has been widespread in this new model of the distribution electrical network, which has found application in the smart grid. It is necessary to find a solution that would bring economic advantages to both the DSO and the end-users in this contest. Power Quality and Custom Power are used in electric systems to refer to two separate things. PQ, which defines a single standard that all distribution system operators must adhere to letter and in full. The DSO manages its network to handle the power quality concerns, but the outcome may meet the needs of certain end-users,

while others may need an improvement in their voltage profile. As a result, the custom requirements may not be totally met by this standard, and the word CP is used to denote the requirements of the end-user community.

Hong, L., et al. (2018) [23] addressed the resonance issue in a parallel inverter based integrated system. Harmonic interaction among inverter and grid display a diverse range of complex features that endanger the stability and quality of the system due to interactions. To explore the resonance issue in grid connected with multi inverter, they devised a technique based on resonance modal analysis and participation factor calculations for harmonic resonance analysis. Firstly, an analytical technique based on impedance is applied, which is then extended to a power distribution network with MI having LCL filter as well as proportional resonant controllers, as well as other power distribution networks. The RMA is then introduced in order to explore the resonant interactions between inverters and the power grid. In particular, the transfer functions and the suggested technique are used to address the harmonic resonance characteristics of the system while taking into account the change in number of inverter, various inverter combinations as well as important components of the system. At the end of the research work, simulations on the PSCAD / EMTDC are discussed time based. The outcomes of the case study demonstrate that, recommended strategy is successful.

Jasiński, M., et al. (2021) [24] investigated a virtual power plant which is operational in Poland. The VPP includes a number of smaller dispersed resources in addition to a hydropower plant of 1.25 MW capacity and a 0.5 MW storage system. Multipoint power quality data were collected from the previously described VPP over a lengthy period of time. Then, utilizing cluster analysis, correlation analysis, and the global index technique, it was possible to get a conclusion regarding the relationship in point of PQ for five linked measurement points in the same time period. In order to reduce the amount of data that required to be processed and investigate the link between phase values, global indicators were employed instead of PQ parameters.. Outliers are very expected to exist in a large dataset of this kind, and outliers may have an impact on the correlation findings. As a result, cluster analysis (k-means method, Chebyshev distance) was used to identify and reject them from consideration. At the end, the association between power quality global indicators obtained from various measurement stations was investigated further. It provided generic information about the relationship between VPP units at the point of PQ. Both Pearson's rank correlation coefficients and Spearman's rank correlation coefficients were taken into consideration throughout the inquiry.

Jasiński, M., et al. (2020) [25] introduced the concept and application of the global power quality index to assess the multipoint power quality collected in the VPP zone.

Selected conventional 10-minute aggregated PQ characteristics form the basis of the GPQI, which is synthesized and further extended by extreme 200 millisecond values of changes in voltage as well as voltage harmonic distortion. For this evaluation, they used actual data from the VPP area's main substation, plant based on hydro (HPP), and systems of energy storage to test proposed GPQI (ESS). Using the suggested index, it was shown that the substation's relationship to HPP and ESS could be determined.

Jasiński, M., et al. (2021) [26] presented an investigation that is based on a real virtual power plant. The VPP in Poland includes hydropower plants as well as energy storage systems, all of which are operational (ESS). When it comes to power quality (PQ) difficulties, cluster analysis, which is a typical approach of data mining, was chosen for the particular study. The data utilized in this study contains twenty six weeks of power quality multipoint synchronic measurements for five sites that are associated with VPP. A variety of input databases for cluster analysis are discussed in depth in this research. In addition to the use of standard PQ parameters as an input, a global index was proposed as an alternative. As a result, the size of the input database can be reduced, while still retaining the data attributes necessary for clustering. In addition, the topic of determining the best number of cluster choices is examined in detail. Finally, an evaluation of the clustering findings was carried out in order to ascertain the effect of the VPP on the power quality level.

Jasiński, M., et al. (2021) [27] addressed power quality problems. The analysis reported here is based on multipoint, synchronized data collected from five sites all linked to VPP, as described before. The authors' study proposes and examines the usage of a single global index in a power system instead of traditional power quality indicators. Furthermore, one new worldwide power quality indicator was presented as a result of their research. Once the PQ measurements and global indexes had been collected, they were utilized to create databases values as input for the Cluster Analysis procedure. The aforementioned cluster analysis was conducted in order to identify the short-term operating circumstances of virtual power plant which were particularly favourable from the standpoint of PQ. This was accomplished by the use of the Ward algorithm, which is a hierarchical clustering technique. They also discuss the use of the cubic clustering criteria to cluster analysis in order to aid in the process. Then, in order to ensure that the general information about the reason for the condition's existence was available, the evaluation of the acquired condition was carried out making use of the global index. Furthermore, report noted that the use of the global index resulted in a decrease in database size of around 74 percent, without any loss of the characteristics of the data.

Jasiński, M., et al. (2020) [28] investigated a VPP in Poland, which contains hydropower plants and systems for storing

energy. The challenges of in quality of power were chosen for a more in-depth investigation. Power quality levels were measured in four different locations over a 26-week period using multipoint synchronic measurements at each location. The research is related to the use of a global index in single-point assessment and the use of a method based on site-based assessment. In addition, the issue of flagged data is examined in detail. At the end of the process, and evaluation of the influence of VPP on the PQ level is performed.

Jasiński, M., et al. (2020) [29] proposed the concept of combining cluster analysis (CA) and global power quality indices to analyse long-term power quality data (GPQIs). The suggested method identifies and evaluates different power quality levels driven by varied conditions of operation of an power network in electrical systems (EPN). CA is used to recognize when the power quality data changes. With CA data, GPQIs may produce a simple evaluation of the power quality status. The aggregated data index and the flagged data index are proposed worldwide power quality indexes for 10 minute data and events that have been combined, respectively. Several studies were conducted using actual measurements on an power network which has generation which is distributed (DG) feeding the sector of copper mining. Studies evaluated suggested method's ability to determine the influence of Distributed Generation as well as other network variables on power quality levels. Findings show that the suggested strategy is useful for comparing data gathered in recognized clusters. The suggested approach also collects data from multiple measurement locations inside an EPN's observable region in a synchronized manner. Thus, the proposed method is one of the analytical approaches for typical multi-parameter power quality data analysis focused to specific measurement areas.

Jasiński, M., et al. (2020) [30] introduced the use of data mining (DM) in long-term power quality (PQ) measurements. Ward algorithm was chosen as the cluster analysis approach to create an automated splitting of the Power Quality measurement data using a cluster analysis technique. In a mining sector electrical power network (EPN) with the dispersed generation, the measurements were carried out in a laboratory setting (DG). The findings suggest that the use of a ward algorithm in PQ data ensures segmentation in terms of the work of the dispersed generation, as well as other critical operating conditions, when using the ward approach. (For example reconfiguration or more harmonic contamination). Analysis described here was carried out in the context of the area-related method, in which first linking of all measured data points is done. The significance rate was created to determine the qualities that have a substantial impact on the data categorization. It is calculated as Another aspect of the paper dealt with the decrease in the the input database size used for the simulation. The decrease in input data by 57

percent ensured a classification agreement of 95 percent as compared to the classification agreement of the whole database.

Katić, V. A., & Stanisavljević, A. M. (2018) [31] proposed a new method for the detection of voltage dips based on a part of a harmonic footprint, an intelligent Power quality incidents are detected and classified using an algorithm. They wanted to develop dependable detection method for dips in voltage detection in the 1 millisecond time span. Many approaches for estimation of harmonics in real-time were tested and compared to find which was the most effective. Mathematical function is used to represent the footprint, which is then used for smart voltage drop detection via the use of a recurrent neural network. It was determined analysing signals from measurements obtained in the actual distribution system of 680 records, simulations using the 13 bus IEEE test grid, and laboratory tests to see if suggested approach was effective for detection of dips in voltage. Tests and verification are performed on the detection rate (reliability) and the speed with which voltage dips are detected. In addition, the future research prospects for the approach under consideration are discussed in detail.

Katyara, S., et al. (2017) [32] studied the model of an industrial network and of the Total Harmonic Distortion analysis was performed (THD) in the power system. By using HAPF, the total harmonic distortion (THD) value was maintained far below the 8 percent threshold suggested by European Standard EN 50160. With the use of HAPF, power factor enhancement was obtained as a result. The power quality theorem was implemented to calculate the hysteresis control parameters, which was then utilized to create the filter. The results reported in the study article demonstrate the effectiveness of the suggested filter since the total harmonic distortions in voltage as well as current were limited to two percent. Power factor of the system was enhanced as a result of the filter design. The most significant contribution of this study is that the P-Q methodology using HAPF was shown to be the most cost-effective method of improving power quality.

Khorasani, P. G., et al. (2017) [33] presented a new design of the hybrid AC/DC microgrid for optimization of the smart grid's effectiveness. Improvement in power quality, power flow control, compensation of reactive power, and the power swings elimination are the important characteristics of this design, this makes use of the DC microgrid's capacity while also introducing the UPQC-DC, a novel unified power quality conditioner with control schemes that are appropriate for two back to back interface converters between the AC and DC microgrids. For the first time, the suggested strategy ensures the achievement of all of the aforementioned objectives in grid integrated and isolated modes, respectively. For testing the suggested strategy, many Matlab simulations are carried out.

Kitzig, J. P., et al. (2018) [34] introduced a power quality measurement system. It gives current as well as synchronous voltage data at mains frequency in the size of 215 samples per cycle, thanks to its high sample rate, which is achieved by the use of a linear interpolation unit. The main frequency estimation unit locks the phase of the measured voltage and outputs the synchrophasor, frequency, rate of change of frequency, as well as sampling rate for interpolation output. This method is being tested in simulations against current standards as well as a phenomenon not yet considered by these standards: low-frequency inter harmonic disturbances such as ripple control signals, which are common in today's power grids but are not yet considered by these standards. Compromising on standard compliance under transitory situations must be made in order to desensitize the system to these threats in order to achieve this. Following that, the first measurements made using an evaluation system are examined in order to provide an initial picture of the system's reaction to genuine signals.

Kovalenko, D. V., et al. (2018) [35] Under the condition of current resonance, the computation of a non stationary non sinusoidal mode of the power supply system was reported (parallel resonance). A study was conducted to determine whether or not higher harmonics filtering was required. In order to do so, the real level of higher harmonics and other unified power quality indicators were monitored, and oscillograms of network mode parameters and HH spectrum were generated. Fluke 435 and the Metrel 2792A power quality analyzers were used to test the unified power quality indices. Both instruments were certified and calibrated before use. These instruments are compliant with current international power quality standards as well as other reference documents. With the help of calculations, it was feasible to estimate resonance frequencies at which the present resonance mode execution is possible. The maximum overvoltage ratios at several sites along the PSS under investigation were also established.

Kumar, A., & Rathore, P. K. (2021) [36] studied how to use a backpropagation (BP) control method to execute DSTATCOM is a three stage delivery static compensator which is capable of load balancing and zero voltage reactive power compensation in accordance with nonlinear loads. They used BP based control to identify the critical dynamic weight. To estimate reference source streams, BP based control is frequently utilized to calculate the load streams' receptive power segments. The use of neural networks to regulate power efficiency devices is a new study topic in power engineering. The extraction of components of harmonic defines the balancing instruments' output. In this example, DSTATCOM and UPFC are employed to balance. A DSTATCOM model is developed by a computerized signal processor and then implemented to particular operating conditions. Using the provided control

mechanism, DSTATCOM may be run on a different kinds of workloads. To calculate the load's active and reactive power components the BP based control approach is adopted . It will detect power quality signal issue in real-time. Continuity, differentiability, and non-decreasing monotony define this algorithm. Unlike DSTATCOM, the UPFC method does not switch off the device under bad situations. The simulation model is built in ANFIS and result is tested under varied conditions. The ANFIS result is suitable for varied loads using the specified control approach. Use MATLAB/Simulink results to validate the suggested approach.

Liu, Q., Li, Y., Hu, S., & Luo, L. (2019) [37]proposed a transformer integrated filtering system for suppression of harmonics in the dc supply provided to the industry. The proposed TIFS has the advantages of lowering losses in transformer, greater harmonic elimination ability, and greater integration of equipment in high power industrial applications, among other things, because it is intended for an electric environment with high current and significant harmonic contamination, as well as an installation space with limited planning area. TIFS is short for transformer-integrated field-bus system. More information on the inductive filtering transformer's winding configuration with integrated reactor can be found here. The electromagnetic decoupling model of TIFS is developed by taking into account the impact of residual weak coupling and other factors. The interaction among the zero impedance designed filtering winding and the decoupling winding is next explored in order to determine the design parameter's limited operating range. Detailed explanations of the control approach, as well as the transformer design process, are provided. Finally, a working prototype of TIFS has been built in the laboratory. In addition, the experimental findings demonstrate that the suggested filtering mechanism is feasible and successful in practice.

Lucas, A., et al. (2015) [38] analyzed four measurement sets performed during the full EV charging cycle, with each harmonic amplitude and phase angle behaviour .The THD and TDD in voltage and current were also computed and compared to IEEE519, IEC 61000/EN50160 standards. The harmonic phase angles of two rapid charging cars linked to the same feeder were also modeled. Overall, TDD is a better indication than THD since it utilizes the peak current (IL) value rather than fundamental current, which might lead to incorrect conclusions. It is recommended that TDD be included in IEC / EN standard revisions. The harmonics of order 11 and 13 did not meet 5.5 percent restriction in IEEE 519 for the charger examined (5 percent and 3 percent respectively in IEC61000). Variations in the fundamental wave's preferred range. The average phase angle variation across vehicles attached to the same feeder was determined to be less than 90°. Increasing the number of cars (IL) reduces the standard limits, which finally exceeds them due

to the upstream short circuit current (ISC). The harmonic constraint comes first, before the power limitation. The first restriction on chargers is not the upstream power circuit's power capacity, but the harmonic pollution limitations.

Naderipour, A., et al. (2020) [39] proposed, a fuzzy logic controller , in order to develop a optimized susceptance function so that the electrical profile could be improved and the SVC capacitance can also be reduced . Simulation results show that using an SVC-based fuzzy strategy to determine the coefficient of the susceptance function is most successful method. Results show that when the suggested methodology is used in conjunction with the proposed method, the system's harmonic currents are reduced and the voltage profile is improved significantly. As a result, the findings show that, in the event of EAF load, SVC has the ability to quickly correcting for its impact as well as improving the system's power quality. It is possible to stabilize the active power received rapidly and eliminate oscillations of power by ensuring that the bus voltage is maintained and voltage oscillations are eliminated. With the implementation of an improved SVC-based fuzzy technique, the power quality issues associated with EAF applications are eliminated. Additionally, the performance of the suggested technique has been tested in comparison to mathematical methods used in earlier research, demonstrating that the new method is better in terms of minimizing voltage oscillations and lowering harmonic currents.

Nalcaci, G., et al. (2020) [40] introduced the Harris Hawks Optimization method of elimination of harmonics in a traction motor drive based VSI .With selective harmonic elimination technique based on pulse-width modulation, the primary goal was elimination of lower order harmonics by solving equations which are nonlinear in nature while maintaining the basic characteristic of the system. When solving the equations for a two level, three phase inverter, Harris Hawks Optimization method is used, as discussed in paper. The method employs seven skill operations in conjunction with an acceptable group strategy to imitate the hunting behaviour of nature's most intelligent species, carried out by swarms of Harris Hawks. The accuracy and convergence probability of this technique is greater than those of the grey wolf optimizer (GWO). The calculation and comparison of HHO and GWO are carried out using the MATLAB program. The results of the simulation show that HHO is better than GWO in terms of attaining exact switching angles and a greater convergence rate than the latter. The simulation experiments are carried out on a traction motor drive platform of rating 135KW in the laboratory and are used to verify the results obtained using MATLAB Simulink. Results of the experiments revealed that the accuracy of re-enactment information and the achievement of the HHO approach was proved by the test information obtained.

Nikolaev, A. A., (2020) [41] A comparative study of two versions of frequency converter and active rectifier was offered based on the region of their influence on the supply network. When comparing the first and second models, the frequency of the converter was totally replicated in the first model, however in the next model, an inverter and synchronous motor were replaced with a current source. To investigate, two simulation models of a frequency converter with a three level active rectifier were designed and implemented in the Matlab Simulink programme using a 12 pulse circuit. The harmonic content of the applied current and mains voltage at the point where the frequency converter is attached is being studied. The feasibility of using simplified modelling of the frequency converter and effective rectifier to assess power quality in industrial businesses' power systems is examined and concluded.

Ranjan, A., et al. (2019) [42] suggested a Dual Second Order Generalized Integrator PLL based control solution for solar grid integrated systems with distribution static compensator capabilities on three phase three wire, single stage. Under unbalanced grid situations, this DSOGI method may assist in attenuating harmonics in current/voltage as well as estimating symmetrical components of current/voltage in a short amount of time. The sequence components cause the fundamental component in load currents to be elicited by the sequence components. The MPPT is supported by an incremental conductance based approach. The suggested system is modeled and tested in the MATLAB. In the laboratory, a prototype is created and subjected to a variety of load tests. According to the test findings, the suggested system's control technique is valid under both steady-state and dynamic scenarios, such as unbalanced load as well as variation of insolation level. According to IEEE-519 standard, essential characteristics such as THD as well as percentage of imbalance of voltage phasor and current phasor are measured and determined to be adequate.

Ranjan, A., et al. (2020) [43] studied loop dual second-order generalized integrator phase-locked loop (DSOGI-PLL) with an in loop filter based control approach single stage, three phase solar grid integrated control loop. a system with unusual grid power conditions, uneven conditions of load, and various levels of solar-grid-interfaced system. Such as single stage, three phase three wire system with anomalous grid voltage, imbalanced load, and changing levels of solar insolation DSOGI implemented with in loop filter algorithm reduces harmonics, removes dc offset, and predicts sequence components for both voltage and current. For computing the reference magnitude of grid currents, this approach extracts the basic component of the load current is highly nonlinear. No dc offset as well as no dominating harmonics of double frequency exist in these basic current components even with unbalanced loads. Asymmetrical grid voltages need correct unit templates to sustain sinusoidal and balanced grid currents. Aside from that, PLL

uses these positive sequence voltages to calculate the phase necessary for magnitude and angle calculations. An incremental conductance-based approach is used to maintain the dc link voltage at the maximum powerpoint. The simulation is done in MATLAB. IEEE-519 standard is used to test a laboratory prototype.

Ruuskanen, V., (2020) [44] has done investigation of cost of the operations and investments of an industrial-scale alkaline electrolyzer for water with 4 different rectifier configurations which are practically used. Data show that rectifiers using thyristor have inadequate quality on both the AC and DC sides, resulting in non-optimal specific energy consumption (SEC) and a substantial reactive power component in the water electrolyzer. Topologies based on Transistor have the potential to reduce the SEC of the electrolyzer by up to 4.5 percent compared to the typical thyristor bridge with six pulse. Reactive power results in extra expenditures, which may be incurred via the purchase of compensating equipment or the payment of recurring allowances. A second DC to DC converter employed to improve the electrolyzer power quality, however this would add to the system's complexity as well as cost while not totally removing the system's reactive power output. A modular, insulated-gate bipolar transistor (IGBT) single-stage bridge rectifier is proposed as an alternate method of delivering enhanced quality power for the electrolyzer as well as the electrical grid, as well as for other applications.

Shair, J., et al. (2021) [45] The developing power system stability concerns, classification, and research potential for power systems with a high share of renewables as well as power electronic were studied. Conventional power system, which has been in place for decades, is experiencing a rapid transformation, with two main characteristics: Renewable energy generators that use intermittent sources such as wind and solar, as well as power electronic devices in generation, transmission, and distribution systems, such as EV as well as microgrids (for example, wind turbine converters and solar power inverters), are becoming more common (for example, electric vehicles and microgrid). The flexibility of power systems has been considerably influenced by the advancement of contemporary power systems with dual high penetration, i.e., high input renewable energy and high use of power electronic devices, producing new stability concerns.

Shklyarskiy, Y., (2020) [46] analysed the available mechanisms for which are used for identifying the contribution of voltage at consumers end to distortion of voltage at a PCC. The approaches studied do not accurately determine the cause of harmonic distortions, or they are difficult to apply. They presented a novel approach for locating high harmonics. The application of compensating devices such as reactive power compensation devices and passive harmonic filters in a grid operating mode with two linked consumers was investigated. The use of harmonic

filters is proven to be the most promising way for assessing the consumer's contribution to voltage distortion. Current research uses computer simulations of an existing power grid to which indirect power users are connected. These approaches may be used to measure power quality and shareholding among customers linked at a single coupling point. Moreover, practically every business already has such facilities in operation.

Shukl, P., & Singh, B. (2019) [47] The delta-bar-delta neural network (NN) was investigated for its ability to function optimally by supplying active power to the loads and residual energy in the grid, which is a function of distribution static compensator capabilities such as harmonic mitigation, load balancing, and power factor improvement. The control technique allows for independent weight adjustment, reducing model complexity and computing time under atypical grid situations. The combinational neural structure in the estimate process improves the accuracy of the NN-based control mechanism. The system also meets the IEEE-519 standard for preserving power quality. An incremental conductance based MPPT approach allows for efficient solar photovoltaic array use. The suggested system's behavior is validated using simulation data. The prototype is also validated, and the findings show dependable functioning under non-ideal grid settings with variable load, voltage, and solar insolation.

Tran, T. S., (2019) [48] focused on autonomous multi-islanded entities and seamless reconnection to the main grid, as well as the future power system's potential to self-heal. Minimizing power quality concerns in such controller based entities with or without intercommunication is an important part of their job description. As distributed generation (DG) penetration increases, the future power system will be able to adapt quickly to any problems that arise with it by splitting into independent islanded entities in order to avoid the DGs disconnection. Customers benefit as a consequence of the high quality as well as consistent electricity that is provided to them.

Yilmaz, M., et al. (2019) [49] In January and July, researchers experimented with the effects of photovoltaic (PV) panel operating conditions, inverter output power, and grid power quality in a power plant with an 8 MW capacity in Burdur, Turkey. An ANN was also used to determine power at the inverter output under various operating settings, as well as an effort was made to establish the ideal operating parameters for the inverter. The output power at the node of the inverter, power factor and frequency values were utilised as input data in the ANN design, while the output power produced by PV panels, radiation intensity, relative humidity, and temperature measurements were used as output data; By applying the gathered data, it was attempted to predict the levels of the elements influencing the inverter output power and efficiency in terms of optimal operating conditions and efficiency in order to ensure the

integration of the energy generated from the solar power plant. When compared to the experimental data, the success rate of the ANN outcomes was seen to be more than 99 percent.

From the above investigation, we can conclude that Most FD techniques are open-loop and use Fourier series analysis. By multiplying the input by a set of trigonometric functions (sine/cosine) at different frequencies, Fourier series analysis is a powerful mathematical tool. The Discrete Fourier Transform is often used to determine the results. Using computer technology, DFT can estimate grid signal characteristics with more selectivity and accuracy than previous approaches. Using A/D conversion of the input signals allows real-time implementation of DFT and requires frequent sampling and updating of the input signals. This method requires N^2 complex multiplication and N^2-N complex addition to calculate the N samples. As a consequence, it was seldom employed before the microprocessor.

3. Proposed Methodology

The following steps are going to follow by the author for future work for research:

- a. DSTATCOM implementation based on the SRF theory, in which the production of reference current is mostly reliant on the phase information included in the grid signal. The switching pulses generated by this reference current are used to run DSTATCOM to meet the reactive power requirement of the load connected at PCC, as shown in Figure 1.
- b. The proposed (MDSOGI-FLL) and conventional (DSOGI-FLL) algorithms are used to calculate the DSTATCOM's performance under normal conditions and in the presence of an offset component in the utility signals. The phase (frequency) information is calculated by the proposed (MDSOGI-FLL) and conventional (DSOGI-FLL) algorithms.
- c. With the help of simulation findings, it is possible to compare the robust performance of the suggested MDSOGI-FLL for frequency estimation with that of the standard DSOGI-FLL for reference current generation.

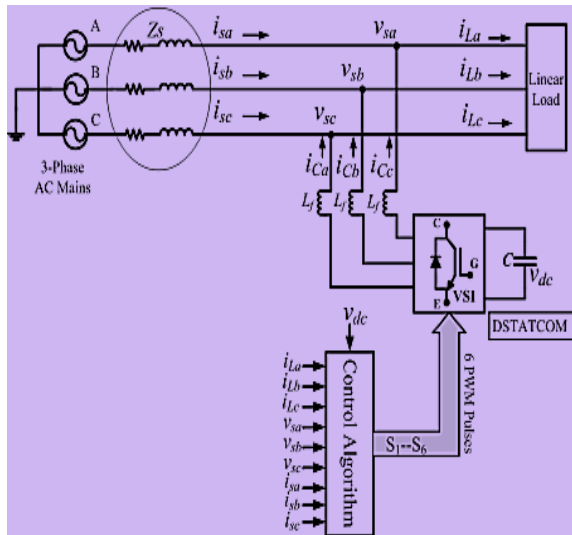

Fig. 1. Schematic configuration of DSTATCOM

In the author next work, the author will investigate the performance of DSOGI-FLL and the suggested MDSOGI-FLL based frequency estimation method for use in the DSTATCOM application in the presence of an idealized offset error. When using the MDSOGI-FLL method in the DSTATCOM program, the grid current will be free of dc offset, and the THD will be substantially below 5%, according to the simulation results derived from this algorithm.

4. Conclusion

It is concluded the microgrid idea incorporates Renewable Energy Systems (RES) into the Electrical Power System (EPS) as a way to create clean energy, fulfill consumer energy needs, and protect the rapidly dwindling fossil fuel reserves. In order to execute the necessary management and power conversion, these renewable energy sources (RES) are frequently interfaced with the grid utilizing power electronic converters. Nonetheless, Voltage Source Converters (VSCs) generate current and voltage harmonics, which have a detrimental influence on the Power Quality of a micro grid and have the potential to cause equipment damage or failure. In the face of uncertainties, such as those resulting from design parameter selection or system parameter changes, the amount of harmonic distortion of many VSCs may be greatly influenced and difficult to forecast. When dealing with VSC harmonic distortion levels in the face of uncertainty, it is necessary to use statistical methodologies.

Acknowledgment

The primary author owes a debt of gratitude to Professor, Dr. Prabodh Khampariya of SSSUTMS, Sehore, M.P., and my research co-guide Associate Professor Dr. Shashikant Bakare of AISSMS IOIT, Pune, for their technical advice on many study themes.

References

- [1] Abdoos, A. A., Mianaei, P. K., &Ghadikolaei, M. R. (2016). Combined VMD-SVM based feature selection method for classification of power quality events. *Applied Soft Computing*, 38, 637-646.
- [2] Abdullazyanov, E. Y., Fedotov, A. I., Zaripova, S. N., Fedotov, E. A., Chernova, N. V., &Vagapov, G. V. (2015). Theoretical Basis of the Mathematical Modeling of Thyristor Converters for Calculation Current and Voltage Harmonics in Power System. *Modern Applied Science*, 9(6), 320.
- [3] Alfieri, L., Bracale, A., & Larsson, A. (2017). New power quality indices for the assessment of waveform distortions from 0 to 150 kHz in power systems with renewable generation and modern non-linear loads. *Energies*, 10(10), 1633.
- [4] Almutairi, M. S., &Hadjiloucas, S. (2019). Harmonics mitigation based on the minimization of non-linearity current in a power system. *Designs*, 3(2), 29.
- [5] Al-Ogaili, A. S., Ramasamy, A., Hoon, Y., Verayiah, R., Marsadek, M., Juhana, T., &Rahmat, N. A. (2020). Time-domain harmonic extraction algorithms for three-level inverter-based shunt active power filter under steady-state and dynamic-state conditions-an evaluation study. *International Journal of Electrical & Computer Engineering* (2088-8708), 10(6).
- [6] Askarian, I., Eren, S., Pahlevani, M., & Knight, A. M. (2017). Digital real-time harmonic estimator for power converters in future micro-grids. *IEEE Transactions on Smart Grid*, 9(6), 6398-6407.
- [7] Bajaj, M., Singh, A. K., Alowaidi, M., Sharma, N. K., Sharma, S. K., & Mishra, S. (2020). Power quality assessment of distorted distribution networks incorporating renewable distributed generation systems based on the analytic hierarchy process. *IEEE Access*, 8, 145713-145737.
- [8] Baraniak, J., &Starzyński, J. (2020). Modeling the impact of electric vehicle charging systems on electric power quality. *Energies*, 13(15), 3951.
- [9] Blazek, V., Petruzela, M., Vantuch, T., Slanina, Z., Mišák, S., &Walendziuk, W. (2020). The estimation of the influence of household appliances on the power quality in a microgrid system. *Energies*, 13(17), 4323.
- [10] Bottura, F. B., Oleskovicz, M., Le, T. D., & Petit, M. (2019). Optimal positioning of power quality meters for monitoring potential conditions of harmonic resonances in a MV distribution system. *IEEE Transactions on Power Delivery*, 34(5), 1885-1897.
- [11] Brunoro, M., Encarnação, L. F., &Fardin, J. F. (2017). Modeling of loads dependent on harmonic voltages. *Electric power systems research*, 152, 367-376.

- [12] Bubshait, A. S., Mortezaei, A., Simoes, M. G., & Busarello, T. D. C. (2017). Power quality enhancement for a grid connected wind turbine energy system. *IEEE Transactions on Industry Applications*, 53(3), 2495-2505.
- [13] Buzdugan, M. I., & Balan, H. (2017). Power system harmonics issues in some end user facilities. In 2017 52nd International Universities Power Engineering Conference (UPEC) (pp. 1-6). IEEE.
- [14] Cai, W., Wu, L., Cui, Y., & He, S. (2020). Uncertainty Principle and Power Quality Sensing and Analysis in Smart Substation. *Sensors*, 20(15), 4281.
- [15] Chokkalingham, B., Padmanaban, S., & Blaabjerg, F. (2018). Investigation and comparative analysis of advanced PWM techniques for three-phase three-level NPC-MLI drives. *Electric Power Components and Systems*, 46(3), 258-269.
- [16] Christe, A. J., Negrashov, S., & Johnson, P. M. (2020). Design, implementation, and evaluation of open power quality. *Energies*, 13(15), 4032.
- [17] Das, S. R., Ray, P. K., Sahoo, A. K., Balasubramanian, K., & Reddy, G. S. (2020). Improvement of power quality in a three-phase system using an adaline-based multilevel inverter. *Frontiers in Energy Research*, 23.
- [18] Filipović-Grčić, D., Filipović-Grčić, B., & Krajtner, D. (2017). Frequency response and harmonic distortion testing of inductive voltage transformer used for power quality measurements. *Procedia engineering*, 202, 159-167.
- [19] Gnacinski, P., & Tarasiuk, T. (2016). Energy-efficient operation of induction motors and power quality standards. *Electric Power Systems Research*, 135, 10-17.
- [20] Gokozan, H., Taskin, S., Seker, S., & Ekiz, H. (2015). A neural network based approach to estimate of power system harmonics for an induction furnace under the different load conditions. *Electrical Engineering*, 97(2), 111-117.
- [21] Gorjani, O. M., Bilik, P., & Vanus, J. (2019). Application of optimized deterministic methods in long-term power quality. In 2019 20th International Scientific Conference on Electric Power Engineering (EPE) (pp. 1-5). IEEE.
- [22] Hafezi, H., & Faranda, R. (2017). Power quality and custom power: Seeking for a common solution in LV distribution network. In 2017 IEEE International Conference on Environment and Electrical Engineering and 2017 IEEE Industrial and Commercial Power Systems Europe (EEEIC/I&CPS Europe) (pp. 1-6). IEEE.
- [23] Hong, L., Shu, W., Wang, J., & Mian, R. (2018). Harmonic resonance investigation of a multi-inverter grid-connected system using resonance modal analysis. *IEEE Transactions on Power Delivery*, 34(1), 63-72.
- [24] Jasiński, M. (2021). Combined Correlation and Cluster Analysis for Long-Term Power Quality Data from Virtual Power Plant. *Electronics*, 10(6), 641.
- [25] Jasiński, M., Sikorski, T., Kaczorowska, D., Kostyła, P., Leonowicz, Z., Rezmer, J., ... & Bejmert, D. (2020). Global power quality index application in virtual power plant. In 2020 12th International Conference and Exhibition on Electrical Power Quality and Utilisation-(EPQU) (pp. 1-6). IEEE.
- [26] Jasiński, M., Sikorski, T., Kaczorowska, D., Rezmer, J., Suresh, V., Leonowicz, Z., ... & Prus, P. (2021). A Case Study on Data Mining Application in a Virtual Power Plant: Cluster Analysis of Power Quality Measurements. *Energies*, 14(4), 974.
- [27] Jasiński, M., Sikorski, T., Kaczorowska, D., Rezmer, J., Suresh, V., Leonowicz, Z., ... & Prus, P. (2021). A case study on a hierarchical clustering application in a virtual power plant: detection of specific working conditions from power quality data. *Energies*, 14(4), 907.
- [28] Jasiński, M., Sikorski, T., Kaczorowska, D., Rezmer, J., Suresh, V., Leonowicz, Z., ... & Janik, P. (2020). A case study on power quality in a virtual power plant: Long term assessment and global index application. *Energies*, 13(24), 6578.
- [29] Jasiński, M., Sikorski, T., Kostyła, P., Leonowicz, Z., & Borkowski, K. (2020). Combined cluster analysis and global power quality indices for the qualitative assessment of the time-varying condition of power quality in an electrical power network with distributed generation. *Energies*, 13(8), 2050.
- [30] Jasiński, M., Sikorski, T., Leonowicz, Z., Borkowski, K., & Jasińska, E. (2020). The application of hierarchical clustering to power quality measurements in an electrical power network with distributed generation. *Energies*, 13(9), 2407.
- [31] Katić, V. A., & Stanisavljević, A. M. (2018). Smart detection of voltage dips using voltage harmonics footprint. *IEEE Transactions on Industry Applications*, 54(5), 5331-5342.
- [32] Katyara, S., Shah, M. A., Staszewski, L., & Soomro, J. (2017). Harmonics compensation in industrial power network using Hybrid Active Power Filter (HAPF) in dq frame. *Sindh University Research Journal-SURJ (Science Series)*, 49(4), 881-888.
- [33] Khorasani, P. G., Joorabian, M., & Seifossadat, S. G. (2017). Smart grid realization with introducing unified power quality conditioner integrated with DC microgrid. *Electric Power Systems Research*, 151, 68-85.
- [34] Kitzig, J. P., Schlaghecke, S., & Bumiller, G. (2018). Power quality measurement system with PMU functionality

- based on interpolated sampling. *IEEE Transactions on Instrumentation and Measurement*, 68(4), 1014-1025.
- [35] Kovalenko, D. V., Kisselyov, B. Y., & Ivanova, E. V. (2018). Calculation of Resonant Modes for Power Supply Systems and Development of Measures on Higher Harmonics Filtering. In 2018 International Conference on Industrial Engineering, Applications and Manufacturing (ICIEAM) (pp. 1-5). IEEE.
- [36] Kumar, A., & Rathore, P. K. (2021). Analysis and Implementation of Artificial Neural Network Techniques for Power Quality Enhancement using DSTATCOM.
- [37] Liu, Q., Li, Y., Hu, S., & Luo, L. (2019). A transformer integrated filtering system for power quality improvement of industrial DC supply system. *IEEE Transactions on Industrial Electronics*, 67(5), 3329-3339.
- [38] Lucas, A., Bonavitacola, F., Kotsakis, E., & Fulli, G. (2015). Grid harmonic impact of multiple electric vehicle fast charging. *Electric Power Systems Research*, 127, 13-21.
- [39] Naderipour, A., Abdul-Malek, Z., Gandoman, F. H., Nowdeh, S. A., Shiran, M. A., Moghaddam, M. J. H., & Davoodkhani, I. F. (2020). Optimal designing of static var compensator to improve voltage profile of power system using fuzzy logic control. *Energy*, 192, 116665.
- [40] Nalcaci, G., Yildirim, D., & Ermis, M. (2020). Selective harmonic elimination for light-rail transportation motor drives using harrishawks algorithm. In 2020 IEEE International Conference on Environment and Electrical Engineering and 2020 IEEE Industrial and Commercial Power Systems Europe (EEEIC/I&CPS Europe) (pp. 1-6). IEEE.
- [41] Nikolaev, A. A., Gilemov, I. G., & Antropova, L. I. (2020). Features of the Mathematical Modeling of Frequency Converters with Active Rectifiers for power quality analysis in internal power supply systems. In 2020 IEEE Conference of Russian Young Researchers in Electrical and Electronic Engineering (EIConRus) (pp. 774-778). IEEE.
- [42] Ranjan, A., Kewat, S., & Singh, B. (2019). DSOGI-PLL based solar grid interfaced system for alleviating power quality problems. In 2019 National Power Electronics Conference (NPEC) (pp. 1-6). IEEE.
- [43] Ranjan, A., Kewat, S., & Singh, B. (2020). DSOGI-PLL with in-loop filter based solar grid interfaced system for alleviating power quality problems. *IEEE Transactions on Industry Applications*, 57(1), 730-740.
- [44] Ruuskanen, V., Koponen, J., Kosonen, A., Niemelä, M., Ahola, J., & Hämäläinen, A. (2020). Power quality and reactive power of water electrolyzers supplied with thyristor converters. *Journal of Power Sources*, 459, 228075.
- [45] Shair, J., Li, H., Hu, J., & Xie, X. (2021). Power system stability issues, classifications and research prospects in the context of high-penetration of renewables and power electronics. *Renewable and Sustainable Energy Reviews*, 145, 111111.
- [46] Shklyarskiy, Y., Skamyin, A., Vladimirov, I., & Gazizov, F. (2020). Distortion load identification based on the application of compensating devices. *Energies*, 13(6), 1430.
- [47] Shukl, P., & Singh, B. (2019). Delta-bar-delta neural-network-based control approach for power quality improvement of solar-PV-interfaced distribution system. *IEEE Transactions on Industrial Informatics*, 16(2), 790-801.
- [48] Tran, T. S., Nguyen, D. T., & Fujita, G. (2019). The analysis of technical trend in islanding operation, harmonic distortion, stabilizing frequency, and voltage of islanded entities. *Resources*, 8(1), 14.
- [49] Yilmaz, M., Kayabasi, E., & Akbaba, M. (2019). Determination of the effects of operating conditions on the output power of the inverter and the power quality using an artificial neural network. *Engineering Science and Technology, an International Journal*, 22(4), 1068-1076.
- [50] A.O.Mulani and P.B.Mane, "An Efficient implementation of DWT for image compression on reconfigurable platform", *International Journal of Control Theory and Applications*, Vol.10 No.15, 2017.
- [51] S. S. Swami and A. O. Mulani, "An efficient FPGA implementation of Discrete Wavelet Transform for image compression", *International Conference on Energy, Communication, Data Analytics and Soft Computing (ICECDS)*, 2017
- [52] A.O.Mulani and P.B.Mane, "Area Efficient High Speed FPGA Based Invisible Watermarking for Image Authentication", *Indian Journal of Science and Technology*, Vol.9. No.39, Oct. 2016.
- [53] P. B. Mane and A. O. Mulani, "High Speed Area Efficient FPGA Implementation of AES Algorithm", *International Journal of Reconfigurable and Embedded Systems*, Vol. 7, No. 3, November 2018, pp. 157-165
- [54] A.O.Mulani and Dr.P.B.Mane, "Fast and Efficient VLSI Implementation of DWT for Image Compression", *International Journal for Research in Applied Science & Engineering Technology*, Vol.5 Iss. IX, pp. 1397-1402, 2017.
- [55] Pratima Amol Kalyankar, Altaf O. Mulani, Sampada P. Thigale, Pranali Gajanan Chavhan and Makarand M. Jadhav, "Scalable face image retrieval using AESC technique", *Journal Of Algebraic Statistics* Volume 13, No. 3, p. 173 – 176, 2022
- [56] Dr. P. B. Mane and A. O. Mulani, "High throughput and area efficient FPGA implementation of AES algorithm",

International Journal of Engineering and Advanced Technology, Vol. 8, Issue 4, April 2019

[57] A. O. Mulani and Dr. P. B. Mane, “Secure and area Efficient Implementation of Digital Image Watermarking on Reconfigurable Platform”, International Journal of Innovative Technology and Exploring Engineering, Vol. 8, Issue 2, Dec. 2018

[58] Kulkarni P.R., Mulani A.O. and Mane P. B., “Robust Invisible Watermarking for Image Authentication”, In Emerging Trends in Electrical, Communications and Information Technologies, Lecture Notes in Electrical Engineering, vol. 394, pp. 193-200, Springer, Singapore, 2017.

[59] A.O.Mulani and Dr.P.B.Mane, “Watermarking and Cryptography Based Image Authentication on Reconfigurable Platform”, Bulletin of Electrical Engineering and Informatics, Vol.6 No.2, pp 181- 187,2017

[60] A.O.Mulani and Dr.P.B.Mane, “Area Efficient High Speed FPGA Based Invisible Watermarking for Image Authentication”, Indian Journal of Science and Technology, Vol.9. No.39, Oct. 2016. ISSN 0974-5645

[61] Kashid, M.M., Karande, K.J., Mulani, A.O. (2022). IoT-Based Environmental Parameter Monitoring Using Machine Learning Approach. In: Kumar, A., Ghinea, G., Merugu, S., Hashimoto, T. (eds) Proceedings of the International Conference on Cognitive and Intelligent Computing. Cognitive Science and Technology. Springer, Singapore. https://doi.org/10.1007/978-981-19-2350-0_5