

Effects of Zero Velocity Update on Total Displacement for Indoor Inertial Positioning Systems

Faruk ULAMIS^{*1}, Murat LUY², Ertugrul CAM³, Ibrahim UZUN⁴

Accepted : 11/03/2017 Published: 30/06/2017

Abstract: In this paper; the effects of Zero Velocity Update method, which is one of the most important components of indoor inertial positioning systems, on total displacement is studied. For this purpose, acceleration and angular velocity measurements on three-axes are obtained by a low-cost foot-mounted inertial measurement unit while walking. The obtained acceleration values are processed and velocity and total displacement are estimated by using double integration. Velocity and displacement estimations were done at the end of each step with and without ZUPT algorithm and the results have been compared. Furthermore, in order to understand ZUPT algorithm well, a rectangular shape is plotted with the system containing IMU and microprocessor by stopping at every corner. ZUPT algorithm is implemented at each stop on the corners of the rectangular shape. The results are plotted in MATLAB. Effects of the errors on total displacement are pointed out.

Keywords: IMU, Indoor Positioning, ZUPT.

1. Introduction

In parallel with the development of the technology, navigation systems become a necessity which is used widely in our daily life. This necessity is provided mostly by GNSS (Global Navigation Satellite Systems) with high accuracy levels. However, most of the daily life is spent indoors like school, work or shopping malls. GNSS signals are either blocked or poorly received for indoor position localization. Therefore, for indoor positioning, other methods should be used.

Broadly, Indoor positioning can be separated into two categories. The first one requires infrastructure setup. In this method, the equipment placed in buildings or indoor areas like sensors and beacons should be set up beforehand. These methods are performed by using systems like infrared (IR) [1], Wi-Fi [2], Ultra Wide Band (UWB) [3], RFID [4] and Bluetooth [5]. The disadvantage of the infrastructure based system is that the equipment used for the infrastructure can be damaged from flood, fire, and earthquake. The second way for indoor positioning is self-contained systems [6], [7]. The most used method of self-contained systems is inertial measurement unit (IMU) based systems.

In recent years, thanks to the development of micro electro mechanic systems (MEMS) technologies, IMU's become smaller, cheaper and consumes much less energy. Being cheaper and smaller size caused these sensors prone to error like drift. The values containing this error grow square with the time while calculating velocity and displacement during double integration [8]. So, estimation of position becomes impossible. Foxlin has designed an inertial sensor based shoe-mounted system to dispel these errors increasing exponentially while integration processes

[9]. The velocity of this system has forced to be zero in every step as a result of nature of walk. In scientific literature, this method called Zero Velocity Update and IMU based errors become zero every step and errors cannot increase continuously.

In this study, three-axes acceleration values are obtained from shoe-mounted IMU in order to understand the importance of ZUPT. The double integration process was done with the obtained acceleration values and then velocity and total displacement figures were plotted. ZUPT method was implemented to velocity and figures of velocity and total displacement was plotted at the same time. Figures implemented ZUPT and unimplemented ZUPT were compared to each other. Furthermore, with the setting up another system containing IMU and microcontroller, the rectangular shape was plotted by stopping every corner. Total displacement with and without ZUPT was plotted and compared to each other.

2. Materials and Methods

In this study, the designed system containing a microprocessor and IMU is shown in figure 1. Microprocessor and 6-degree-of-freedom IMU have been communicated with the i2c protocol. Obtained acceleration and angular velocity values were transferred to the microprocessor and then these values measuring in body frame transform to navigation frame and transferred to a computer via serial port. Transferred acceleration and angular velocity values in the computer have been converted velocity and displacement estimation with first and second integration respectively using MATLAB.

¹ Electronic and Automation, Hacilar Huseyin Aytemiz Vocational School of Higher Education Kirikkale University, Kirikkale, Turkey

^{2,3} Engineering Faculty, Electrical and Electronics Engineering, Kirikkale University, Kirikkale, Turkey

⁴ Engineering Faculty, Mechanical Engineering, Kirikkale University, Kirikkale, Turkey

* Corresponding Author: Email: farukulamis@hotmail.com

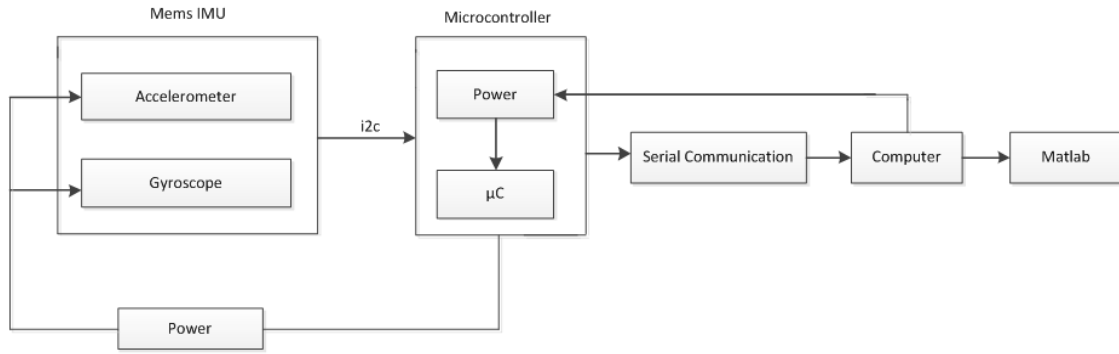

Figure1. Block diagram of designed system

2.1. Estimation of Position

It was shown that the conversion of acceleration into displacement using double integration figure 2.

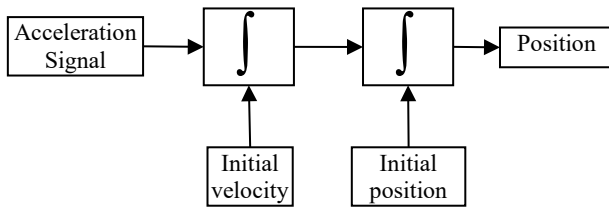

Figure2. Double integration process

Values transferring from IMU are discrete time values with the sampling frequency of microcontroller. So, integration process for transforming acceleration to velocity and displacement must be done with digital integration. There are various ways for digital integration. In this study, we used trapezoidal integration methods that can be seen Equation 1.

$$y(n) = y(n-1) + \frac{1}{2f_s} [x(n-1) + x(n)], \quad n > 0 \quad (1)$$

Where x is integrand, y is the output of integration and f_s is sampling frequency.

Trapezoidal integration acts as a first order hold on the system. In figure 3, a 1 Hz sine wave is integrated using trapezoidal methods [10].

To get the velocity and displacement by using trapezoidal integration method from acceleration values Equation 2 and Equation 3 are used respectively.

$$V(n) = V(n-1) + \frac{1}{2f_s} [a(n-1) + a(n)], \quad n > 0 \quad (2)$$

$$D(n) = D(n-1) + \frac{1}{2f_s} [V(n-1) + V(n)], \quad n > 0 \quad (3)$$

Where a is acceleration, V is velocity and D is displacement.

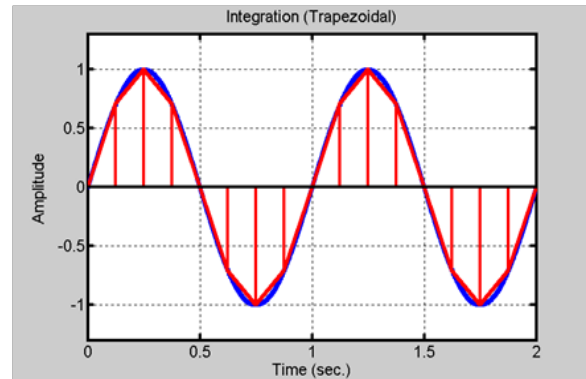

Figure3. Trapezoidal integration

2.2. Zero Velocity Update

Numerical double integration of measured accelerations involves errors that must be carefully minimized: time integration significantly amplifies any measurement error. Unfortunately, digital recordings of accelerations usually comprise many errors. Consequently, velocity and displacement traces obtained by integrating accelerations are commonly flawed by drifts that produce unrealistic results [11]. Therefore, inertial sensors are not used alone generally. Some other sensors must be used to correct these errors. To do this, GNSS signals are used especially to correct these errors in military application [12].

Correcting error using GNSS signals is not possible because of signal blockage and attenuation problem for the indoor environment. So, another method must be used for correction of errors to do sensitive positioning. For this correction process, IMU is mounted to shoe and error correct stand phase using nature of walk.

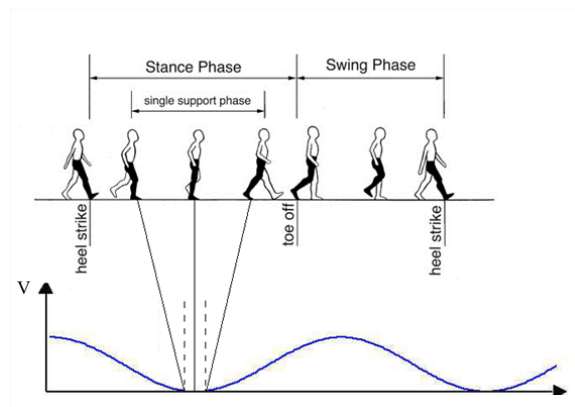

Figure4. Zero velocity update

Velocity force to be zero while stance phase as seen figure 4. This process is done in every step while walking so the accumulation of errors is restrained. In scientific literature, it is called Zero Velocity Update.

There are various methods to detect ZUPT like the magnitude of acceleration [13], artificial neural network based [14] and magnitude of angular velocity [15]. All these methods use three axes acceleration and angular velocity values obtaining from IMU and there must be a threshold to detect ZUPT. Tri-axis acceleration and angular velocity graphs while walking can be seen figure 5.

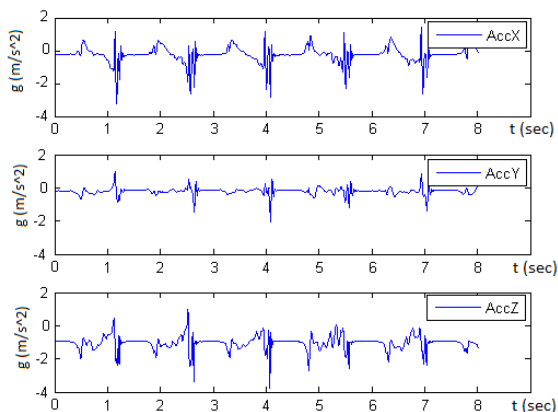

Figure 5. Tri-axis accelerometer measurement while walking

In this study, X-axis acceleration values while walking have been utilized to detect starting and finishing points of ZUPT periods. Acceleration values below threshold have been detected and velocity has been forced to zero while in these periods.

3. Experimental Results

In this study, two experimental setups have been constituted. For the first setup, a system containing IMU and microcontroller has been mounted to foot as seen figure 6 and three steps have been taken.



Figure 6. Foot mounted system

Velocity has been estimated from X-axis acceleration values transferring to MATLAB with serial communication using Equation 2. The figures of estimated velocity have been obtained with and without ZUPT as seen figure 7.

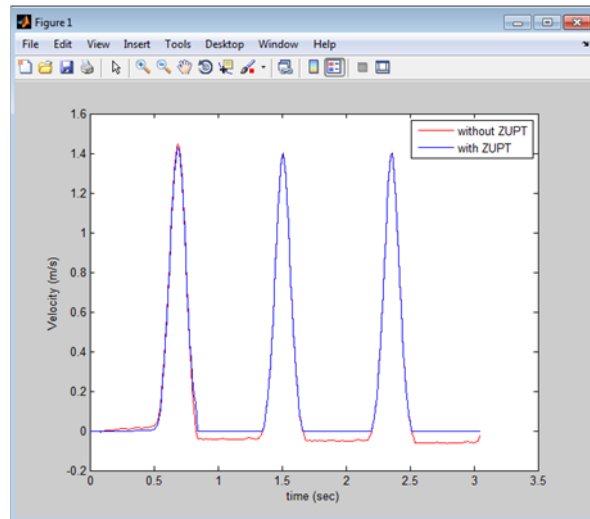

Figure 7. Velocity with and without ZUPT

Total displacement calculations have been made with Equation 3 using estimated velocity values with and without ZUPT. Mean error for velocity and total displacement can be seen in table 1.

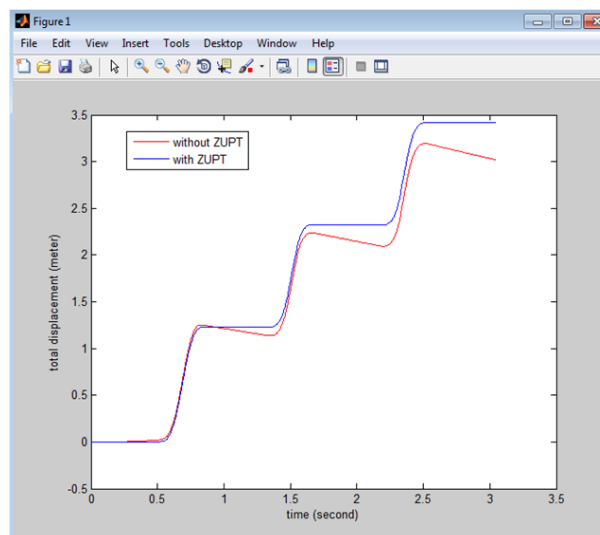

Figure 8. Displacement with and without ZUPT

	Mean error (velocity) %	Mean error (displacement) %
1.step	0.21	7.524
2.step	0.25	9.871
3.step	0.30	11.631
mean	0.253	9.675

Table 1. Velocity and displacement errors

For the second experimental setup, a system containing IMU and microcontroller has been moved along the x and y-axis with the rectangular shape. The system has been stopped every period of movement to implement ZUPT algorithm and every movement has been done perpendicularly seen figure 9.

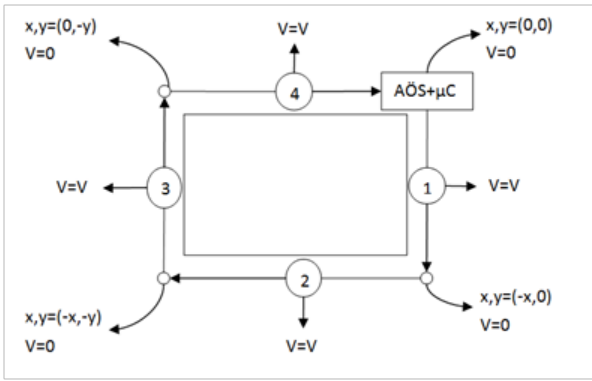

Figure 9. Plotting rectangular shape with IMU and microcontroller

ZUPT method has been implemented at the corner of a rectangular shape when there is no movement. Total displacement at the x-axis, y-axis, and two dimensions with and without ZUPT algorithm have been obtained as shown figure 10, figure 11 and figure 12 respectively.

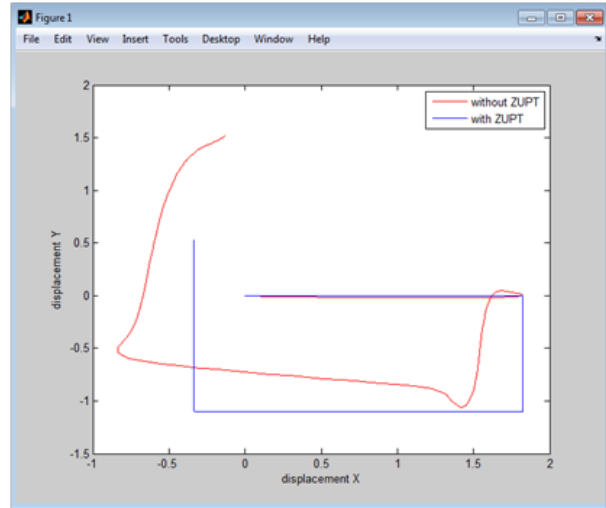

Figure 10. Two-dimensional total displacement with and without ZUPT

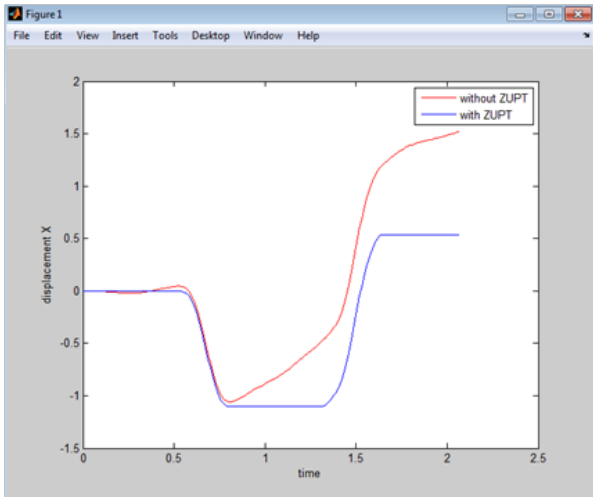

Figure 10. Total displacement along X-axis

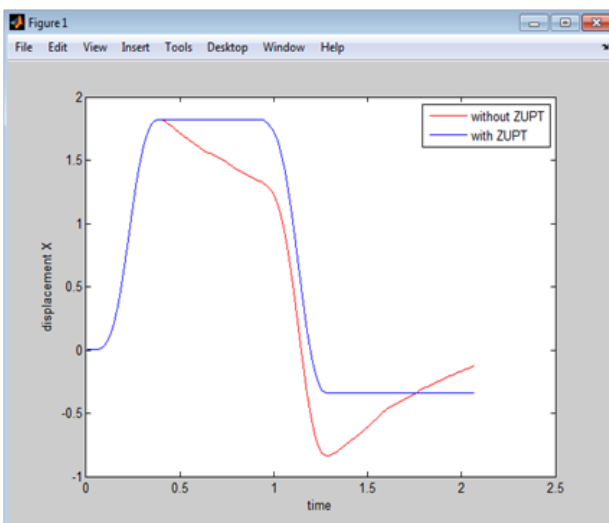

Figure 11. Total displacement along Y-axis

4. Conclusion

In this study, effects of ZUPT method on IMU using especially indoor positioning system have been investigated. Two experimental setups have been established to understand this effect clearly. In the first setup, three steps have been taken with the foot mounted system and velocity and total displacement has been estimated with the double integration. Total velocity error and total displacement error at the end of the three-steps has been found 0.29459 % and 11.631% respectively.

References

- [1] Martin-Gorostiza, E., Meca-Meca, F. J., Lázaro-Galilea, J. L., Salido-Monzú, D., Martos-Naya, E., & Wieser, A. (2014, November). Infrared local positioning system using phase differences. In *Ubiquitous Positioning Indoor Navigation and Location Based Service (UPINLBS)*, 2014 (pp. 238-247). IEEE.
- [2] Bozkurt Keser, S., Yayan, U., (2016). A Hybrid Approach for Indoor Positioning. In *International Journal of Intelligent Systems and Applications in Engineering (IJISAE)*, 2016, 4(Special Issue), (pp. 162–165).
- [3] Tiemann, J., Schweikowski, F., & Wietfeld, C. (2015, October). Design of an UWB indoor-positioning system for UAV navigation in GNSS-denied environments. In *Indoor Positioning and Indoor Navigation (IPIN)*, 2015 International Conference on (pp. 1-7). IEEE.
- [4] Seco, F., Plagemann, C., Jimenez, A. R. & Burgard, W., (2010). Improving RFID based indoor positioning accuracy using Gaussian processes. In *Proceedings of International Conference on Indoor Positioning and Indoor Navigation (IPIN 2010)*. Zurich, Switzerland, 15-17 September 2010.
- [5] R. Agrawal and A. Vasalya, (2012). *Bluetooth Navigation System using Wi-Fi Access Points*. Cornell University Library, Tech. Rep. arXiv:1204.1748.
- [6] Li, Y., Zhuang, Y., Lan, H., Zhang, P., Niu, X., & El-Sheimy, N. (2016). Self-Contained Indoor Pedestrian Navigation Using Smartphone Sensors and Magnetic Features. *IEEE Sensors Journal*, 16(19), 7173-7182.
- [7] Pajaziti, A., Avdullahu, P., (2014). SLAM – Map Building and Navigation via ROS#. In *International Journal of*

- [8] M. Arraigada, M. Partl, (2006). Calculation of displacements of measured accelerations, analysis of two accelerometers and application in road engineering. Conference paper STRC 2006
- [9] Foxlin, E. (2005). Pedestrian tracking with shoe-mounted inertial sensors. *IEEE Comp. Graph. Appl.* 2005, 25, 38-46.
- [10] Lance D. Slifka, (2004). An accelerometer based approach to measuring displacements of a vehicle body. Horace Rackham School of Graduate Studies of the University of Michigan.
- [11] Boore D. M. (2004). Long-period ground motions from digital acceleration recordings: a new era in engineering seismology. *Proc. International Workshop on Future Directions in Instrumentation for Strong Motion and Engineering Seismology*, Kusadasi, Turkey, Kluher, Dordrecht, The Netherlands (in press), May 17–21, 2004
- [12] Hongyang, B., Kai, X., Jiangfeng, D., & Huiling, X. (2015, July). Design of missile-borne GNSS/SINS tightly-coupled integrated navigation system. In *Control Conference (CCC)*, 2015 34th Chinese (pp. 5348-5353). IEEE.
- [13] Hide, C., T. Botterill, and M. Andreotti, (2009). An integrated IMU, GNSS and image recognition sensor for pedestrian navigation. In *Proceedings of the Institute of Navigation GNSS 2009 Conference*. Fort Worth, Texas.
- [14] Cho, S. Y., and Chan G. P., (2006). MEMS based pedestrian navigation system. *Journal of Navigation* 59, no. 01 (2006): 135-153.
- [15] Skog, Isaac, J-O. Nilsson, and P. Handel, (2010). Evaluation of zero-velocity detectors for foot-mounted inertial navigation systems. In *Indoor Positioning and Indoor Navigation (IPIN)*, pp. 1-6. IEEE.