

## Maximizing Solar Power Output with PV-STATCOM for Reactive Power Compensation in ON-Grid Systems

Mr. Amol A. Suryawanshi<sup>1</sup>, Dr. Ashwani Tapde<sup>2</sup>

Submitted: 12/04/2024 Revised: 24/04/2024 Accepted: 15/05/2024

**Abstract:** As the demand for renewable energy sources increases, solar power has emerged as one of the most promising alternatives. However, solar power generation is inherently intermittent and fluctuates due to weather conditions and other factors. Additionally, the increasing penetration of solar power in on-grid systems poses challenges in terms of maintaining grid stability and ensuring power quality. This research article presents the concept of utilizing a Photovoltaic-Static Synchronous Compensator (PV-STATCOM) for reactive power compensation in on-grid systems to enhance solar power output. The proposed approach combines the benefits of photovoltaic systems and STATCOM technology to achieve improved power quality, grid voltage control, and reactive power management.

**Keywords:** PV STATCOM, harmonics, nonlinear load, power quality, switching devices

### Introduction

The ever-increasing demand for renewable energy has accelerated the adoption of solar power systems worldwide. Solar photovoltaic (PV) systems, which convert sunlight into electricity, have emerged as a prominent solution for clean and sustainable energy generation. However, the intermittent nature of solar power and its susceptibility to grid disturbances present challenges for maximizing the efficiency and stability of solar power output [1].

One critical factor affecting the performance of solar PV systems is reactive power, which is necessary for voltage control and power factor correction in electrical grids. Reactive power compensation plays a vital role in ensuring reliable and optimal power transfer between the solar system and the utility grid, enabling improved power quality and system stability.

To address these challenges, the integration of PV-STATCOM (Photovoltaic Static Synchronous Compensator) has gained attention as an effective solution for reactive power compensation in on-grid solar systems [2-4]. PV-STATCOM is a power electronic device that combines the functionalities

of a STATCOM (Static Synchronous Compensator) and a solar inverter, providing advanced grid support capabilities.

By dynamically injecting reactive power into the grid, PV-STATCOM actively regulates the voltage and power factor of the solar system, ensuring efficient power transfer and minimizing losses. This technology enables the solar PV system to operate at its maximum power point, optimizing energy generation while maintaining grid stability [5].

Moreover, PV-STATCOM offers additional benefits such as flicker mitigation, harmonic suppression, and voltage regulation. Its fast response time and precise control allow for real-time adjustments to varying grid conditions, reducing the impact of grid disturbances and enhancing the overall system performance.

### Literature Review

Ma et al. [10] performed research on reactive power management in transmission and distribution networks. They emphasized the importance of a specific technology called STATCOM, which is a vital feature of the Flexible AC Transmission System (FACTS) and has recently received a lot of attention from researchers. The term "stamp" refers to a type of marking that is used to describe a product. It's a good idea to have a backup plan in place if you want to avoid dealing with the hassle of a broken computer. Because of these features,

<sup>1</sup>Research Scholar, Electrical Department, Dr. APJ Abdul Kalam University, Indore (MP)

<sup>2</sup>Assistant Professor, Electrical and Electronics Engineering Department, Dr. APJ Abdul Kalam University, Indore (MP)  
amol001@gmail.com

STATCOM has become more popular among electrical engineers worldwide, both at home and abroad.

The research of Hassan et al. [11] defined FACTS as the use of solid-state power electronic devices, typically thyristors, to regulate power flow at the transmission level. Significant progress was made in the transmission of electrical power and in electronic technology generally as a result of this. Electrical power and electronic transmission technology have come a long way over the years. These developments were made with the intention of maximizing the advantages of electricity transformation and integrating flexible control systems into energy storage. Prior to the development of FACTS, unreliable traditional procedures were used. In MV or LV distribution networks, these techniques often entailed the use of transformer tap-changers and/or switched capacitors/reactors.

The Institute of Electrical and Electronics Engineers (IEEE) defines a Static Synchronous Compensator (STATCOM) as a self-commutated switching power converter that draws energy from a suitable electric power source. It may be wired into an existing AC power grid and is intended to provide a range of multiphase voltages. A STATCOM is installed with the intention of allowing actual and reactive power exchange to be independently controlled.

In order to ensure system stability and voltage control, reactive compensation is crucial in electric power systems. To provide regulated reactive compensation, STATCOM settings are frequently used. The International Council on Large Electric Systems (CIGRE) and IEEE recommend a three-part functional architecture for a STATCOM.

### **Exploring The Latest Innovations In Statcom Technology**

In order to improve the quality of life for the general public, the government has implemented a system that allows for the rapid deployment of new technologies. Further work has gone towards making the design more compact, simplifying reloading, and reducing harmonic interactions with the power grid.

Currently, numerous technical solutions, including multi-converter ideas, high-voltage pulse-width modulation (PWM) converters, and multilevel converters [7-9], are available on the market. The

term "high-speed" refers to the process of converting electrical energy into mechanical energy. Multilevel converters have been devised to enhance the efficiency of power transmission networks.

### **First Generation of Reactive Power Generation**

The earliest compensators appeared in the early days of reactive power compensation, and they relied on mechanically switched devices. In order to protect the integrity of the system, several factors must be taken into consideration. The four most common types of compensators used at this time were the fixed shunt capacitor (FC), fixed shunt reactor (FR), mechanically switched shunt capacitor (MSC), and mechanically switched shunt reactor (MSR).

### **The second generation**

The power compensators of today are a major step forward in terms of power control technology. Using a self-commutated solid-state voltage source inverter based on thyristors, these compensators function. With this technology, power quality in electrical systems may be precisely and efficiently managed. Different types of these compensators have developed to meet various needs and deal with specific issues in power control.

### **Third generation power compensators**

The second generation of power compensators had certain problems, thus the third generation was designed with a concentration on converting technology to address these issues. There are a number of different types of power flow controllers, such as the (i) static synchronous compensator (STATCOM) (ii) converter-based devices, (iii) unified power flow controller (UPFC) (iv) static synchronous series compensator (SSSC), (v) self-commutated compensator (SCC) (vi) interline power flow controller (IPFC). However, the complexity of the grid and supply system meant that even with the improvements made over the generations, the energy compensators still weren't able to provide the optimal power compensation necessary to ensure reliable power delivery. The trajectory is one of increasing dependability and automation. The basic setup of the STATCOM shown in Figure 1 is the subject of the current investigation. It might be difficult to determine where and how large FACTS devices should be installed in order to achieve the desired improvement in voltage stability.

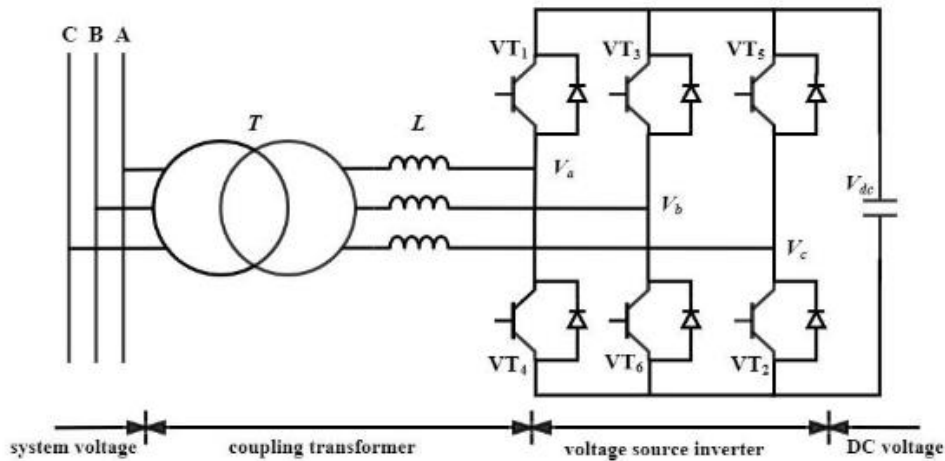

**Fig 1.** Fundamental Architecture of STATCOM

**Methodology**

An investigation was conducted to assess the effectiveness of an innovative technology called Static Synchronous Compensators (STATCOMs) in compensating reactive power in a grid-connected system with a power rating of 90 kW. The main objective was to compare the performance of STATCOMs with traditional fixed capacitors.

To begin with, the researchers developed and analyzed models of the load dynamics for both scenarios. It is crucial to ensure power quality and stability in a grid-connected system by

compensating for reactive power adequately. By employing STATCOMs, the reactive power requirements of the system can be dynamically adjusted to match the load demands.

Furthermore, the proposed architecture aimed to enhance the MPPT of photovoltaic (PV) modules by integrating three essential components: particle swarm optimization (PSO), interval type-2 membership functions, ANFIS approach. This unique combination allowed the sliding mode controller to operate with an adaptable reference voltage, thereby optimizing the efficiency of the PV system.

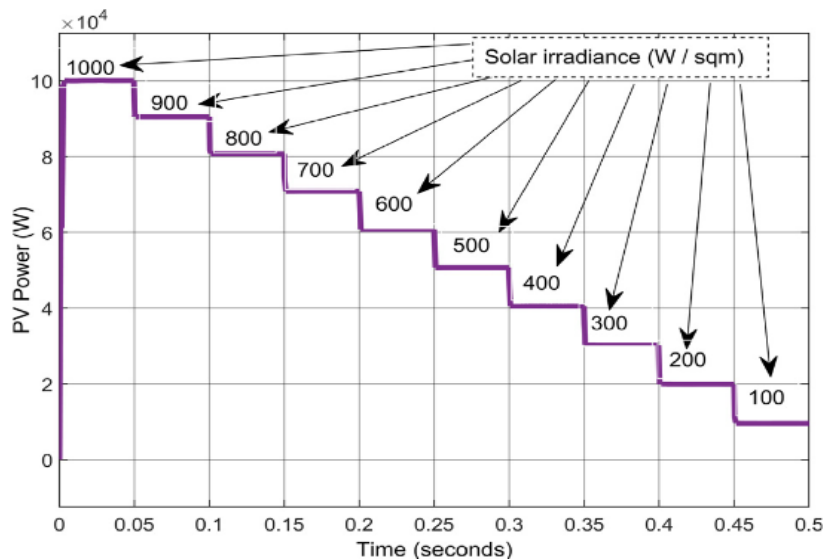

**Fig 2.** Optimizing PV Array Power Output in the Face of Solar Irradiance Fluctuations: A Controller Approach

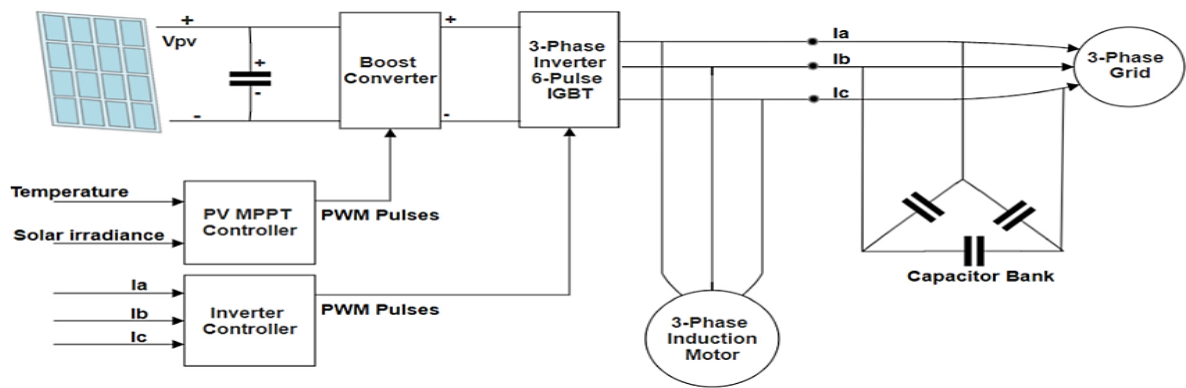

**Fig 3.** Fixed capacitor PV grid connected schematic

When it comes to FACTS, or Flexible Alternating Current Transmission Systems, the Static Synchronous Compensator (STATCOM) is a crucial piece of equipment. It consists of a voltage regulator source converter coupled to a battery. The energy storage device is primarily a capacitor with a reactor serving as a harmonic filter between it and the alternating grid. Its major function is to maintain a stable level of reactive power in transmission networks by either injecting or absorbing power as needed. It is also used often to enhance a network's voltage stability.

The dynamic behaviour of total connected loads motivates the incorporation of STATCOMs in distribution networks, especially those connected to grid-connected photovoltaic (PV) installations or renewable energy sources in general. A set compensation strategy for reactive power consumption may not be the best option given this dynamic nature. Therefore, the STATCOM provides a versatile and customizable method to offset reactive power fluctuations in distribution systems.

The reactive power consumption of PV systems and other grid-connected renewables may be efficiently regulated by using a STATCOM in distribution networks. Since the output of various renewable energy sources tends to fluctuate owing to external causes, the STATCOM can quickly modify its operation to keep the voltage level constant and guarantee effective power

transmission. This flexibility is essential for ensuring that consumers continue to get a reliable and high-quality power supply.

### Result

The STATCOM, short for Static Synchronous Compensator, serves a crucial role as a reactive power compensator in a 90 kW photovoltaic (PV) grid-connected system. By employing advanced control techniques, the STATCOM can regulate the flow of reactive power, ensuring optimal power factor and voltage stability in the system.

In Figure 4, the output power characteristics of the STATCOM are depicted based on a simulation that considers specific load settings. The graph illustrates how the STATCOM responds and adjusts its output power to maintain a stable and efficient operation of the grid-connected system.

Figure 4 shows that the STATCOM was able to provide the load's reactive power requirement of 60 KVAR. The only way to know for sure is to look at the results of the test. Figure 5 shows the terminal voltage waves, the voltage across the DC capacitor, and the injected currents at the point of common coupling (PCC).

The STATCOM's contribution to the system's reactive power demand is critical for achieving and sustaining the necessary power balance. The STATCOM's reactive current control features guarantee that adequate reactive power is delivered to the load at all times.

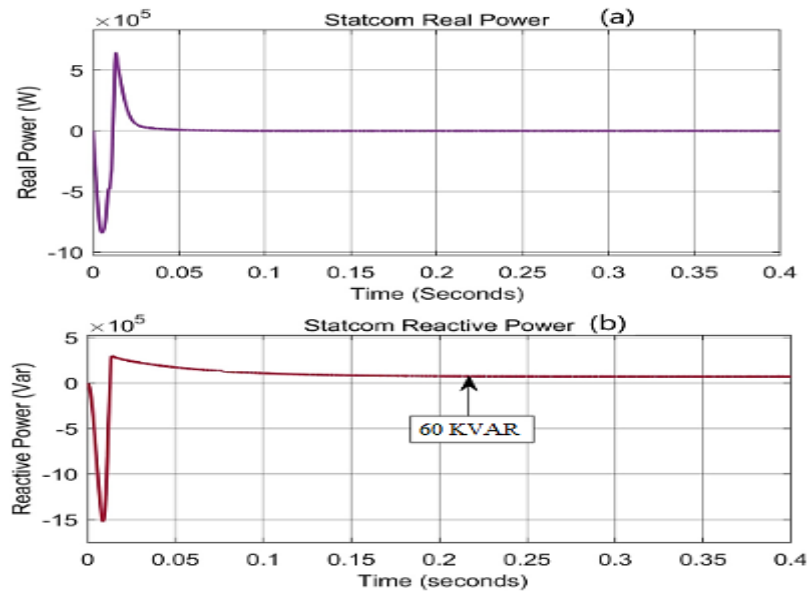

**Fig 4.** a) Active, b) reactive Power Supply by STATCOM

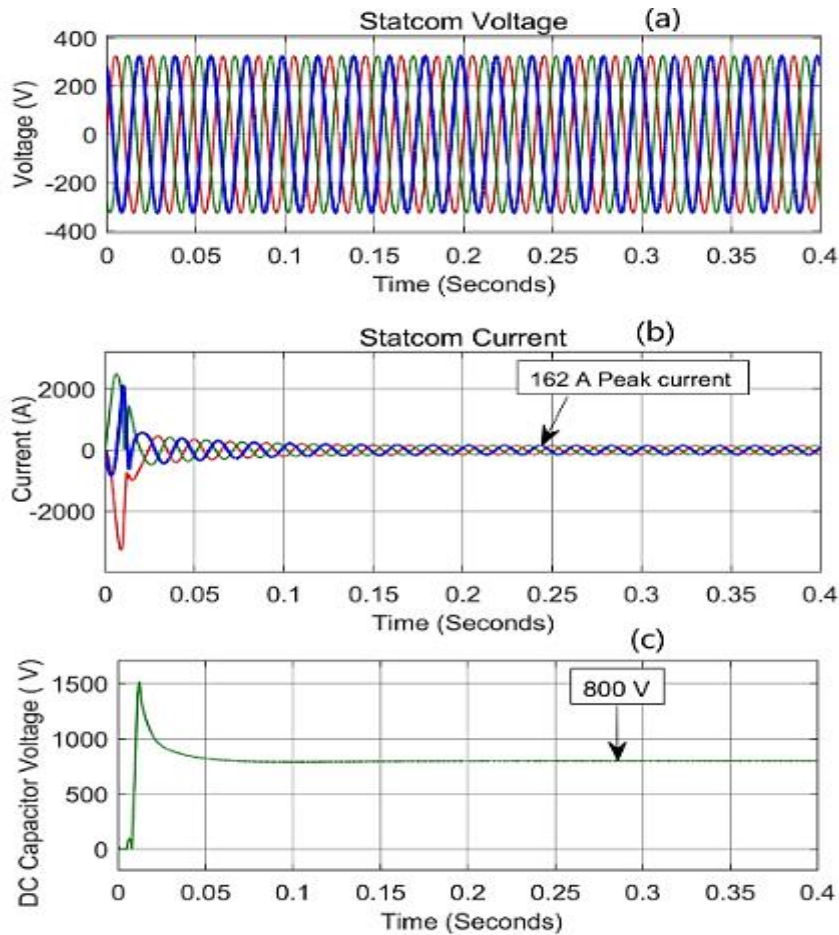

**Fig 5.** Analysis of Output Characteristics for Grid Stability

**Conclusion**

This paper explained the advantages of using STATCOMs for reactive power compensation in grid-connected systems, particularly in the context

of PV systems and other renewable energy sources. The adaptability and flexibility of STATCOMs enable effective management of reactive power variations, ensuring stable voltage levels and reliable power supply to consumers. Further

research and implementation of STATCOMs in distribution networks can contribute to the improvement of power quality and stability in the renewable energy sector.

## References

- [1] M. M, Begovic, I, Kim, M, Kezunovic, "Impact of stochastically distributed renewable PV generation on distribution network," 2016 Power Systems Computation Conference (PSCC), 2016, pp. 1-6, doi: 10.1109/PSCC.2016.7541018.
- [2] D, Solyali, B, Safaei, O, Zargar, G, Aytac, "A comprehensive state-of-the-art review of electrochemical battery storage systems for power grids", International Journal of Energy Research, 2022. Available: 10.1002/er.8451.
- [3] O, Kalaf, D, Solyali, M, Asmael, Q, Zeeshan, B, Safaei, A, Askir, "Experimental and simulation study of liquid coolant battery thermal management system for electric vehicles: A review", International Journal of Energy Research, vol. 45, no. 5 2020 6495-6517, Available: 10.1002/er.6268.
- [4] Awasth VM, Huchche VA. Reactive power compensation using D-STATCOM. Int Conference on Energy Efficient Technol Sustainability (ICEETS) 2016:583-5.
- [5] P, Desai, S, Khule, "Reactive Power Compensation Through Grid Connected PV System Using STATCOM". International Journal for Research in Engineering Application & Management 2016 (IJREAM), 02 05 2016.
- [6] Dixon J, Moran L, Rodriguez J, Domke R. Reactive power compensation technologies: state-of-the-art review. Proc IEEE Dec. 2005;93(12):2144-64.
- [7] Benidris M, Sulaeman S, Tian Y, Mitra J. Reactive power compensation for reliability improvement of power systems. IEEE/PES Trans Distribution Conference and Exposition (T&D) 2016:1-5.
- [8] Liu L, Li H, Xue Y, Liu W. Reactive power compensation and optimization strategy for grid-interactive cascaded photovoltaic systems. IEEE Trans Power Electron Jan. 2015;30 (1):188-202.
- [9] V, Kumar, M, Singh, "Reactive power compensation using derated power generation mode of modified P&O algorithm in grid-interfaced PV system", Renewable Energy, vol. 178 2021 108-117. Available:

10.1016/j.renene.2021.06.035 [Accessed 7 September 2022]

- [10] Y. Ma, A. Huang, and X. Zhou, "A review of STATCOM on the electric power system," 2015 IEEE International Conference on Mechatronics and Automation (ICMA), Beijing, pp. 162-167, 2015.
- [11] H. A. Hassan, Z. H. Osman, and A. E. Lasheen, "Sizing of STATCOM to Enhance Voltage Stability of Power Systems for Normal and Contingency Cases," Scientific Research Open Access, vol. 5, no. 1, pp. 8-18, 2014.
- [12] H. Musa, "An Overview on Voltage Stability Indices as Indicators of Voltage Stability for Networks with Distributed Generations Penetration," International Journal of Science, Technology and Society, vol. 3, no. 4, pp. 214-219, 2015.
- [13] S. Shankari, "Comparison of Electric Springs with Statcom for Flc Based Distributed Voltage Control," International Journal of Professional Engineering Studies, vol. VI, no. 3, pp. 355-362, 2016.
- [14] R. Sirjani, A. Mohamed, and H. Shareef, "Optimal placement and sizing of shunt FACTS devices in power systems using heuristic optimization techniques: A comprehensive survey," Przegląd Elektrotechniczny, vol. 88, no. 10b, pp. 335-341, 2012.
- [15] E. Ghahremani and I. Kamwa, "Optimal Allocation of STATCOM with Energy Storage to Improve Power System Performance," 2014 IEEE PES T&D Conference and Exposition, Chicago, IL, pp. 1-5, 2014.